

Figure 4 Standalone

User Guide

Release Date: 11/9/2022

Original Instructions



TABLE OF CONTENTS

1	FIGURE 4 STANDALONE INTRODUCTION	1
2	FIGURE 4 STANDALONE SAFETY	2
2.1	Figure 4 Standalone Environmental Safety	3
2.2	Figure 4 Standalone Safety Switches	3
2.3	Figure 4 Standalone Material Handling and Safety	3
2.4	Figure 4 Standalone Electrical Safety	5
2.5	Figure 4 Standalone Emergency Shutdown	6
2.6	First Aid and Protective Equipment	6
2.7	Figure 4 Standalone Safety Notice	6
3	FIGURE 4 STANDALONE OVERVIEW	8
3.1	Figure 4 Standalone Upper Build Chamber	8
3.2	Figure 4 Standalone Lower Build Chamber	9
3.3	Figure 4 Standalone Touch Screen and QR-Code Scanner	9
3.4	Figure 4 Standalone Catch Tray	10
3.5	Figure 4 Standalone Resin Tray	10
3.5.1	Tension System	11
3.5.2	Resin Tray Garage	11
3.6	Figure 4 Standalone Print Platform	12
3.7	Figure 4 Standalone Back of Printer	13
3.8	Figure 4 Standalone Pedestal	13
3.9	Figure 4 Standalone Part Cleaning	14
3.10	Figure 4 Standalone Part Drying	14
3.11	LC-3D Print Box	15
4	FIGURE 4 STANDALONE SPECIFICATIONS AND REQUIREMENTS	17
4.1	Figure 4 Standalone Printer Materials and Properties	17
4.1.1	Properties Figure 4 TOUGH CLEAR	17
4.1.2	Properties Figure 4 JCAST-GRN 10	18
4.1.3	Properties Figure 4 TOUGH GRY 10	19
4.1.4	Properties Figure 4 TOUGH GRY 15	19
4.1.5	Figure 4 EGGHELL-AMB 10	20
4.1.6	Properties Figure 4 ELAST-BLK 10	21
4.1.7	Properties Figure 4 FLEX-BLK 10	22
4.1.8	Special Considerations for FLEX BLK 10	23
4.1.9	Properties Figure 4 FLEX-BLK 20	23
4.1.10	Properties Figure 4 HI TEMP 300-AMB	24
4.1.11	Properties Figure 4 High Temp 150C FR Black	25
4.1.12	Properties Figure 4 JEWEL MASTER GRY	26
4.1.13	Properties Figure 4 MED-AMB 10	27

4.1.14	Properties Figure 4 MED-WHT 10	28
4.1.15	Properties Figure 4 PRO-BLK 10	28
4.1.16	Properties Figure 4 Rigid 140C Black	29
4.1.17	Properties Figure 4 Rigid Gray	30
4.1.18	Properties Figure 4 Rigid White	31
4.1.19	Properties Figure 4 RUBBER-65A BLK	32
4.1.20	Properties Figure 4 RUBBER-BLK 10	33
4.1.21	Properties Figure 4 Tough 60C White	34
4.1.22	Properties Figure 4 Tough 65C Black	35
4.1.23	Properties Figure 4 TOUGH-BLK 20	35
4.2	Figure 4 Standalone Material Expiration Date	36

5 FIGURE 4 STANDALONE FACILITY REQUIREMENTS 37

5.1	Figure 4 Standalone 3D Sprint Software	37
5.2	Site Selection - Figure 4 Standalone Printer	37
5.2.1	Figure 4 Standalone Part 1	37
5.2.2	Figure 4 Standalone Part 2	41
5.2.3	Figure 4 Standalone Part 3	41
5.3	Figure 4 Standalone Site Selection - Post Processing Equipment	42
5.3.1	Figure 4 Standalone Third Party Supplies and Equipment	43
5.4	Figure 4 Standalone System Delivery	44
5.5	Figure 4 Standalone System Installation	45
5.6	Figure 4 Standalone Considerations for Material	46
5.7	Figure 4 Standalone Advance Preparation Checklist	47

6 FIGURE 4 STANDALONE SETTING UP YOUR PRINTER 49

6.1	Figure 4 Standalone Necessary Accessories	51
6.2	Figure 4 Standalone Optional Accessories	52
6.3	Figure 4 Standalone Unpacking the Printer	52
6.4	Figure 4 Standalone Unpacking the Pedestal	52
6.5	Figure 4 Standalone Place Printer on Pedestal	52
6.6	Figure 4 Standalone Level the Printer on Pedestal	52
6.7	Figure 4 Standalone Nesting Printers	53
6.8	Figure 4 Standalone Install Carbon Filter	54
6.9	Figure 4 Standalone Turn Printer On	54
6.10	Figure 4 Standalone Printer Activation	55
6.11	Figure 4 Standalone Connect Printer to WiFi with Router	55

7 FIGURE 4 STANDALONE SYSTEM REQUIREMENTS AND SETUP 59

7.1	Figure 4 Standalone Install 3D Sprint Software	59
7.1.1	Set Up Printer On Network	59
7.2	Figure 4 Standalone Accuracy Wizard	60
7.3	Figure 4 Standalone 3D Sprint Additional Documentation	62

8	FIGURE 4 STANDALONE OPERATION	64
8.1	Figure 4 Standalone Touch Screen Overview	64
8.1.1	Status Tab	64
8.1.2	Queue Tab	65
8.1.3	Material Tab	66
8.1.4	Settings Tab	66
8.2	Figure 4 Standalone Prepare and Install the Resin Tray	72
8.2.1	Install Resin Tray	73
8.2.2	Add-Change Material and Scan Bottle	74
8.2.3	Resin Tray Material Cross-Usage	76
8.2.4	Mixing, Stirring, and Curing Chart	77
8.2.5	Fill Resin Tray With Material	80
8.2.6	Mixing Material in the Resin Tray	82
8.3	Figure 4 Standalone Prepare and Install the Print Platform	83
8.3.1	Install Print Platform	83
8.4	Figure 4 Standalone Start Printing	84
8.4.1	Submit Build File via USB	87
8.4.2	Change Material Before Printing	88
8.4.3	QR Code Override	90
8.4.4	Abort a Print Job	93
8.4.5	Submit Build File via Network	96
8.5	Figure 4 Standalone Change Air Filter	96
8.6	Figure 4 Standalone Change Carbon Filter	97
8.7	Figure 4 Standalone When Printer is Idle - Sleep Mode	98
8.8	Figure 4 Standalone Running a Resin Tray Cleaning	99
8.9	Figure 4 Standalone Special Considerations for Rigid 140C Black Material	100
9	FIGURE 4 STANDALONE POST PROCESSING	105
9.1	Figure 4 Standalone Remove Printed Parts From Platform	106
9.2	Figure 4 Standalone Cleaning Printed Parts	107
9.2.1	Cleaning Chart	108
9.2.2	Cleaning Parts Using an Ultrasonic Cleaner	111
9.2.3	Cleaning Parts Manually	112
9.2.4	Specific Gravity Measurement	113
9.3	Figure 4 Standalone Dry the Build Parts	113
9.4	Figure 4 Standalone UV Cure the Parts	114
9.4.1	General Post Curing Requirements	115
9.5	Figure 4 Standalone Sterilization Protocol for MED-AMB 10 and MED-WHT 10	115
9.6	Figure 4 Standalone Considerations for Heating Figure 4 HI TEMP 300-AMB	116
9.7	Figure 4 Standalone Clean Print Platform	117
9.8	Figure 4 Standalone Clean Resin Tray	120
9.9	Figure 4 Standalone Clean Finishing Tools	123
10	FIGURE 4 STANDALONE PRINTER ERROR MESSAGES	124

11	FIGURE 4 STANDALONE SERVICE AND SUPPORT	128
12	FIGURE 4 STANDALONE PREVENTATIVE MAINTENANCE	129
12.1	Cleaning the Printer	129
12.1.1	Clean-Replace the Catch Tray	129
12.1.2	Clean Resin Tray	131
12.1.3	Clean Tension System	131
12.1.4	Clean Membrane Interface Lip	132
12.1.5	Clean Touch Screen and QR-Code Scanner	132
12.1.6	Inspect Printer Lid	133
12.2	Inspect Projector Lens and All Cables	133
12.3	Check Printer Level	134
12.4	Check Print Platform Level	134
12.5	Preventative Maintenance Checklist	136
13	FIGURE 4 STANDALONE TROUBLESHOOTING	137
13.1	Printed Part Quality	137
13.2	Hardware Issues	142
13.3	Part Cleaning Issues	146
13.4	Network Issues	147
14	REPACKING THE FIGURE 4 STANDALONE	152
15	FIGURE 4 STANDALONE CE DECLARATION OF CONFORMITY	155

1 FIGURE 4 STANDALONE INTRODUCTION

Thank you for purchasing the Figure 4 Standalone 3D Printer.

The Figure 4 Standalone Printer is a flexible and efficient projector-based 3D-printing system that produces high-fidelity parts from a broad range of materials. The Figure 4 Standalone Printer uses a digital-projection light source and a special membrane-based resin tray that enables very high print speeds and new material chemistries that provide production-grade properties. It is intended to be used as a three-dimensional output device to create (or to communicate design intent of) durable, end-use parts. Parts produced can be used in all phases of design, from a concept build to functional testing and end-use parts. The Figure 4 Standalone Printer uses all Figure 4 resins for a variety of applications.

These parts are generated in the rapid prototyping (RP) environment under the control of the printer operators. The system must be run by technicians who are trained in proper usage of the printer and resins. All design and process considerations are compatible with an RP environment. The three-dimensional solid parts that are printed consist of different print materials that cure when exposed to 405 nm radiation. The operator pours print material, also called "resin," into the [resin tray](#). Using a proprietary digital projector that 3D Systems has developed, a radiation pattern is cast onto the underside of the resin tray and through to the bottom of the resin. This radiation causes a phase change in the resin that converts it into a solid polymer, adhering to the [print platform](#). After a layer has cured, the elevator moves the print platform up by one layer length and the radiation pattern for the next layer is projected. This process repeats, layer by layer, until the build file is complete. The print platform, along with the part, is removed from the printer and the part is cleaned and post-cured to provide a finished part.

This manual provides users with an understanding of features, system requirements, and operating procedures needed to create finished parts using the Figure 4 Standalone Printer.

Copyright and Corporate Identity

Figure 4® is a registered trademark of 3D Systems.

Improvements

3D Systems may (but shall not be obligated to) make improvements to this document from time to time. However, the Licensed User acknowledges that at any time after the expiration of the date of issuance, 3D Systems may institute a periodic charge or fee payable by the Licensed User in return for ongoing receipt of improvements. It is the responsibility of the Licensed User to provide 3D Systems with current information as to its name and address. The Licensed User also undertakes to notify 3D Systems promptly in the event that it considers any of the data contained in this document to be incomplete or erroneous in any respect, in connection with the Licensed User's particular or general use.

FCC Notice

United States

This equipment has been tested and found to comply with the limits for a Class A digital device, pursuant to Part 15 of the FCC Rules. These limits are designed to provide reasonable protection against harmful interference when the equipment is operated in a commercial environment. This equipment generates, uses, and can radiate radio frequency energy. If it is not installed and used in accordance with these instructions, it may cause harmful interference to radio communications. Operation of this equipment in a residential area is likely to cause harmful interference in which case the user will be required to correct the interference at his/her own expense.

Canada

CAN ICES-3 (A)/NMB-3 (A)

European Union



CAUTION: This is a Class A product. In a domestic environment, this product can cause radio interference in which case the user could be required to take adequate measures.

Korea

사용자 안내문

이 기기는 업무용 환경에서 사용할 목적으로 적합성평가를 받은 기기로서 가정용 환경에서 사용하는 경우 전파간섭의 우려가 있습니다.

Changes or modifications to this equipment not approved by 3D Systems can void the authority of the user to operate this equipment.

2 FIGURE 4 STANDALONE SAFETY



CAUTION: IMPORTANT SAFETY INSTRUCTIONS - READ AND FOLLOW THESE INSTRUCTIONS BEFORE OPERATING Figure 4 Standalone PRINTER.

Introduction

You must read all manufacturer documentation before operating the Figure 4 Standalone Printer. Also, anyone assisting you must have also read the documentation. After reading all the manuals, always follow the safety guidelines and procedures in this section when operating the Figure 4 Standalone Printer.

Customer Safety Program

Before using the Figure 4 Standalone Printer, customers must have a safety program in place. The safety program should do the following:

- Label and point out hazardous equipment, materials, and procedures.
- Explain what to do in an emergency situation.
- Provide information about the hazards of equipment and materials in the form of Safety Data Sheets (SDS). The SDSs are provided with all print materials supplied by 3D Systems.

The information in this chapter supplements the customer's existing safety program. It points out safety considerations that specifically concern the Figure 4 Standalone Printer.

Levels of User



WARNING: DO NOT ATTEMPT TO PERFORM ANY PROCEDURES DESCRIBED IN THIS MANUAL UNLESS YOU HAVE READ THROUGH THE ENTIRE MANUAL FIRST.

There are two levels of users of the Figure 4 Standalone Printer, based on the amount and type of training the user has received. The two levels of users (operators and certified service personnel), are described below.

Operator

Operators are those who have read this User Guide and can perform all the necessary tasks to build a part. The operator may also perform simple maintenance procedures as outlined in this manual.

Certified Service Personnel

Certified service personnel are those who have completed the 3D Systems service training package, and are certified to perform service tasks on the Figure 4 Standalone Printer. Certification may occur at various levels, and certified service personnel should only perform tasks they are authorized and certified to complete.

Safety Design Features in the Figure 4 Standalone Printer

The following design features are provided to reduce potentially hazardous operating conditions:



WARNING: IF ANY OF THE FOLLOWING SAFETY FEATURES FAILS, YOUR ACTIONS MAY BE ALL THAT WILL PREVENT POTENTIALLY HAZARDOUS OPERATING CONDITIONS.

- The design of the radiation-delivery system is intended to prevent radiation from being aimed outside the area of the build chamber.
- The Figure 4 Standalone Printer has been evaluated to IEC 62471 and the internal UV light source classified as 'Risk Group 2' and does not pose a hazard due to aversion response to bright light or thermal discomfort. UV emitted from this product. Eye irritation may result from exposure. Use appropriate shielding.

Safety Symbols and Definitions

The following are safety symbols that are common to 3D Systems guides. Some or all of these symbols may appear in this guide and/or in other Figure 4 Standalone documentation.



CAUTION: Indicates the possibility of loss of data or damage to equipment.



WARNING: INDICATES THE POSSIBILITY OF INJURY TO PERSONNEL.



Wear Protective Gloves: Wear the appropriate gloves when required. For example, when touching surfaces that may contain or have been exposed to materials, wear nitrile gloves. Heat gloves are necessary when touching surfaces that may be hot to ensure burns don't occur.



Hot Surface: A hot surface is accessible in the vicinity of this sign or behind the access panel. Avoid contact. Hot surfaces can cause burn injury or fire. Allow surface to cool before touching. Access panels are for service only and should be opened only by certified service personnel or trained maintenance personnel.



Note: A note signifies important information but not information of a critical content.



Ultraviolet Radiation: Indicates that UV radiation is present.



HARMFUL IRRITANT WARNING: Indicates that skin or eye irritation could result while exposed to a chemical composition

Error Messages

If you see an error message on the Figure 4 Standalone Printer's touch screen, fix the issue to clear the error message before resuming operation.

2.1 Figure 4 Standalone Environmental Safety

The following are environmental issues concerning the Figure 4 Standalone Printer:

- Controlling waste heat is not required for normal operation of the Figure 4 Standalone Printer.
- When you dispose of print materials, refer to the SDS for that material and follow any applicable local, state, and federal regulations.
- All waste products (spilled print material, cleaning solvents, etc.) must be disposed of in accordance with all applicable local, state, and federal regulations.
- Do not clean anything with uncured resin on it in a sink or tub that drains into normal wastewater.

2.2 Figure 4 Standalone Safety Switches

There are three safety switches on the printer, located on: the lid, the front door, and the catch tray. Tripping or defeating any of these switches will abort the current print job and freeze the elevator. The next time you send a job to the printer, the elevator will move back to the home position before printing. Please see the section [Abort a Print Job](#) for more information.

2.3 Figure 4 Standalone Material Handling and Safety



Note: For complete safety information and instructions for use, please read the SDS and User Guide for the Figure 4 resin you are using. These documents are packaged in with each bottle of print material.



HARMFUL IRRITANT WARNING: Avoid skin contact. Avoid breathing in print material fumes.



Wear Eye Protection: Always wear chemical-resistant gloves, such as nitrile, when working near print materials or with partially cured parts. 3D Systems recommends using 100% nitrile gloves; however, other chemical-resistant gloves will suffice. Do NOT use latex gloves, as they do not provide complete chemical protection



Wear Protective Clothing: It is recommended to wear approved protective clothing. Protective clothing includes, but is not limited to: closed-toed shoes, full-length pants, and splash-resistant lab coats or equivalents.



Wear Eye Protection: It is recommended to wear approved goggles when handling print material.

- Always practice standard lab hygiene and follow Personal Protective Equipment (PPE) requirements outlined in this manual.
- Wearing contact lenses when working with print materials is not recommended.
- Avoid breathing in vapors from print material. To avoid breathing in vapors: when opening the build chamber, allow a few seconds to pass before putting your face near the opening. No special facility and/or ventilation modifications should be required to operate the printer in a lab environment.
- Always wash skin thoroughly with a nonabrasive soap and COLD water after working with print materials. DO NOT USE HOT WATER OR SOLVENTS to wash hands, as these will stimulate your pores and result in absorption through the skin. Print material is sensitizing and can cause bad allergic reactions if absorbed through the skin. A person who becomes sensitized to print material should not work around that material in the future.
- If a small amount of resin gets on your clothing, remove the article of clothing as soon as possible (it might be a good idea to have a change of clothes on hand just in case). Have contaminated clothing dry cleaned. DO NOT wash in regular washing machine that drains into wastewater. If a particularly large amount of resin gets on your clothes, it is best to discard them according to all local, state, and federal regulations. Keep contaminated clothing away from food and drinks. Wash hands thoroughly after handling contaminated clothes, even if you wore protective clothing/gloves to handle them.
- Use extreme care when handling solvents that are used to remove excess print material from uncured parts. Some solvents are very flammable. See your solvent's SDS for more information.
- Keep all print materials away from heat, sparks, static discharge, and flame. Print material containers may rupture when exposed to extreme heat. We recommend storing your Figure 4 materials in a fire-resistant storage cabinet. Please refer to the SDS for a particular resin to view its flash point.
- High temperatures may cause a spontaneous polymerizing reaction, generating heat and pressure. Closed containers may rupture or explode during a runaway polymerization. Use a water spray or fog to reduce or direct vapors.
- Fire fighters should use a self-contained breathing apparatus and full protective clothing in the event of a resin fire.
- Do not leave uncured, or liquid, resins in an area where persons who are not knowledgeable about their handling or use may have access to them.
- Keep away from food and drinks.



WARNING: USE NATIONAL FIRE PROTECTION ASSOCIATION CLASS B EXTINGUISHERS SUCH AS CARBON DIOXIDE, DRY CHEMICAL, OR FOAM. A SPRAY OF WATER MIGHT ALSO BE EFFECTIVE. DO NOT USE A DIRECT JET OF WATER OR SMOTHERING TO EXTINGUISH BURNING RESIN OR SOLVENTS.

Print Material Characteristics

The photopolymers used in the print materials may be hazardous if handled improperly. Repeated skin contact with print materials may cause sensitization. Consult the manufacturer's Safety Data Sheet (SDS) for information on specific print materials. For further information on this and related topics, consult the [3D Systems Materials website](#).



WARNING: NEVER MIX DIFFERENT PRINT MATERIALS. DOING SO WILL RENDER BOTH MATERIALS INEFFECTIVE.

Figure 4 Material Storage

Print materials should be stored in the opaque, non-reactive containers in which they were provided, according to the guidelines given in the SDS included with the print material, and according to all applicable regulations (local, state, and federal). Protect print material from sunlight, ambient light, and moisture. Close the resin bottle after each use. Be sure your resin-storage area is dry, dark, and between 5°C-30°C (41°F-86°F). It is preferable to store the resin in a fireproof cabinet. Improperly stored resins may increase in viscosity, and may eventually result in a gelled, polymerized product in the storage container. Materials should be stored in conformance with applicable laws and regulations. The expiration date of the product is mentioned on the product label. If resin is past its expiration date, the product is no longer guaranteed in terms of treatment. 3D Systems is not responsible for losses incurred as the result of improper storage of print material.

Print Material Disposal

Do not dump print material down any drains. Dispose of print material according to the guidelines given in the SDS included with the print material and according to all applicable regulations (local, state, and federal). For more information on print-material disposal, please see the section [Considerations for Resin](#) in the Chapter: Facility Requirements.

Print-Material Spill Containment

A major print-material spill is unlikely during normal use of the Figure 4 Standalone Printer. However, there may be certain situations that require containment of a major resin spill. Your company has the responsibility to define what constitutes a major spill. Clean up spilled print material as quickly as possible, as material will cure under both natural and artificial lighting. Personnel who are involved in cleaning up major spills of print material should wear NIOSH/MSHA approved respirators

designed for use with organic chemical vapors. In addition, each person should wear protective goggles, rubber boots, and 100% nitrile gloves to minimize exposure to print material, which can cause eye, skin, and respiratory irritation, as well as possible skin allergies and respiratory reactions.



WARNING: UNTRAINED PERSONNEL SHOULD BE EVACUATED FROM THE AREA.



WARNING: PRINT MATERIALS ARE FLAMMABLE. CARE SHOULD BE TAKEN DURING PRINT MATERIAL CONTAINMENT AND CLEANUP OPERATIONS.

A supply of dikes and control booms should be stocked so they are available to contain the affected area in the event of a major print-material spill. The spilled print material should then be absorbed on inert, absorbent material and placed into drums for transfer to an approved waste-disposal site. After absorbing all spilled material, clean the spill location with a nonabrasive cloth and IPA. After cleaning up the spill, individuals should wash thoroughly with soap and COLD water. Any clothing touched by resin should be dry cleaned before reuse. If resin has gotten onto your skin or clothes, avoid exposure to sunlight or other UV-light sources until skin and clothing have been cleaned of print material. Repeated or prolonged skin contact may cause sensitization. Vapor may be harmful.

Eliminate sources of ignition. Prevent entry into drains. Absorb spilled resin onto sand, earth or any other suitable adsorbent material. DO NOT absorb onto sawdust or other combustible materials. Resin spills or uncontrolled discharges into wastewater systems must be reported to the appropriate regulatory body. Do not discard resin into drains/surface waters/groundwater. Maximize ventilation after accidental release.

Shelf Life

Print materials are certified for use for 24 months from their date of manufacture. The expiration dates are marked on the material bottle labels. Resins should not be used past their expiration date. The printer will not accept the scan of a resin bottle that is expired.

In-Service Life

In-service life of the print material is defined as the useful life of the material after having been poured into the Figure 4 Standalone's resin tray. The in-service life of print material greatly varies depending on material type, usage and environmental conditions. If the material is exposed to temperatures outside of the normal operating limits, is exposed to UV light, is exposed to particulates or vapors in the air such as dust or fumes, or if contaminants are introduced such as partially cured platforms being placed back into the resin tray, this will shorten the material's in-service life. The types of patterns and builds performed also affect the in-service life of the material. With all this taken into consideration, the in-service life of the material is the same as its expiration date: two years. The material retains its usefulness until a buildup of viscosity or a change in reactivity prevents further processing in the Figure 4 Standalone Printer. All materials require some level of stirring or spinning to retain their properties. You must NOT mix resin from an old resin bottle with resin from a new resin bottle. These resins will be from different batches; and mixing them could render both ineffective. Follow the Instructions for Use of the specific material you are using for complete instructions on getting the most use out of it.

Contamination

Care should be taken when cleaning windows, panels, and other parts of the Figure 4 Standalone Printer. Cleaning products that contain ammonia should not be used because they can contaminate the material. Instead, use a small amount of isopropyl alcohol on a paper towel to clean up spills. Accidental contamination of resins may change the material's performance characteristics to such an extent that acceptable parts can no longer be reliably created.



WARNING: SEALED CONTAINER MAY RUPTURE IF EXPLOSIVELY HOT. PLEASE SEE THE RESIN'S SDS FOR INFORMATION ON ITS FLASH POINT.

Polymerization

Polymerization may occur upon heating the resin bottle. Signs of polymerization of stored resin include container bulging, leaking, the emission of heat, or an unusual odor from the container. If you notice any of these traits, do not use the material and dispose of it according to all local, state, and federal regulations.

2.4 Figure 4 Standalone Electrical Safety

Do not remove any panels or other parts of the printer casing. The printer was designed to minimize operator exposure to electrical hazards during normal operations. All exposed electrical circuits are contained within limited-access cabinets. This is to separate the operator from service and maintenance areas. 100-240VAC power is present in multiple locations throughout the unit. Whenever performing maintenance procedures, power down the machine and unplug AC power if possible.

2.5 Figure 4 Standalone Emergency Shutdown



Note: The Figure 4 Standalone Printer does NOT have an Emergency Stop button. The only way to stop printer operation during an emergency is by unplugging the power cord from the power inlet on the printer.



2.6 First Aid and Protective Equipment

The following paragraphs provide general first-aid procedures and recommendations for protective equipment to minimize the risks from print material exposure. If professional medical attention is necessary, take the Safety Data Sheet (SDS) for the exact print material involved to the attending physician.



Skin Contact: Figure 4 resin may cause sensitization by skin contact. It is irritating to the skin; repeated and/or prolonged contact may cause dermatitis. Wear 100% nitrile gloves and lab coats to avoid skin contact. Should print material come in contact with skin, wash thoroughly with soap and COLD water and immediately remove contaminated clothing and shoes. If skin is irritated, get medical attention. Dry-clean contaminated clothing. Discard contaminated shoes and leather products.



Wear Eye Protection: High vapor concentration may cause irritation. Safety goggles should be worn to prevent accidental splashes of print material into the eyes. If print material comes in contact with the eye, flush immediately with large amounts of COLD water for 15 minutes. Avoid sunlight, fluorescent light, and other ultraviolet light, and obtain immediate medical attention. Eye-wash facilities and a first-aid kit should be readily available and close to the print material.

Contact Lenses

If print material splashes into the eye when contact lenses are worn, flush the eye with water immediately. Verify that flushing has removed the contact lens from the eye. Protect eyes from light and obtain immediate medical attention. Discard contact lenses that come into contact with liquid print material.

Fume Inhalation

Inhaling fumes from Figure 4 resin is irritating to the respiratory system. High atmospheric concentrations may lead to irritation of the respiratory tract, dizziness, headache and anesthetic effects. Do not operate the Figure 4 Standalone Printer without its filter in place. Normal operation of the printer with filter in place should not emit fumes. However, if a person should inhale printer fumes, bring the exposed person to fresh air. Perform CPR if required. If breathing is difficult, give oxygen and obtain immediate medical attention for the person.

Ingestion

Do not induce vomiting. Never induce vomiting or give anything by mouth if the victim is unconscious or having convulsions. Immediately rinse mouth and drink plenty of water. Get medical attention.

2.7 Figure 4 Standalone Safety Notice



CAUTION: Use of controls or adjustments, or performance of procedures other than those contained in any official manual for this machine, may result in hazardous radiation exposure.



Note: Closed light-projection products are not considered to be hazardous.

The Figure 4 Standalone printer incorporates a protective housing and radiation-protective lid, such that there is no exposure or human access to the radiation generated by the light projector during normal operation. The print engine was evaluated to IEC 62471 and classified as Risk Group 2. This means the UV light is only a moderate risk and does not pose a hazard due to aversion response to bright light or thermal discomfort. However, it is still good practice not to stare directly into the projector, particularly when running the machine with an empty resin tray.

All service to the light-projection process machine, the embedded light-projection system, and other components requiring sensor override shall only be performed by 3D Systems Corporation service personnel, their authorized agents, or personnel who have been service trained by 3D Systems Corporation.

Product Labels

The numbers in Item column below correspond to the numbers in the images below.

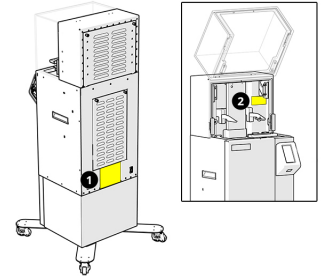

ITEM	DESCRIPTION	QTY	LABEL
1	Product Label - Contains system information and certification symbols	1	
2	Optical-Radiation Warning Sticker Risk Group 2 - Possible hazardous optical radiation emitted from the product. Do not stare at operating lamp. May be harmful to the eyes.	1	

3 FIGURE 4 STANDALONE OVERVIEW

Figure 4 Standalone Printer Components



- A** Upper Build Chamber - Contains the elevator, elevator arms, resin tray, and print platform
- B** Lower Build Chamber - Contains the projector, controller computer, and other components. The operator does not generally have access to view inside this area.

The Figure 4 Standalone Printer is only one component of the complete system. Many accessories and other components make up a Figure 4 Standalone Printer facility. The following sections describe these accessories and components.

3.1 Figure 4 Standalone Upper Build Chamber

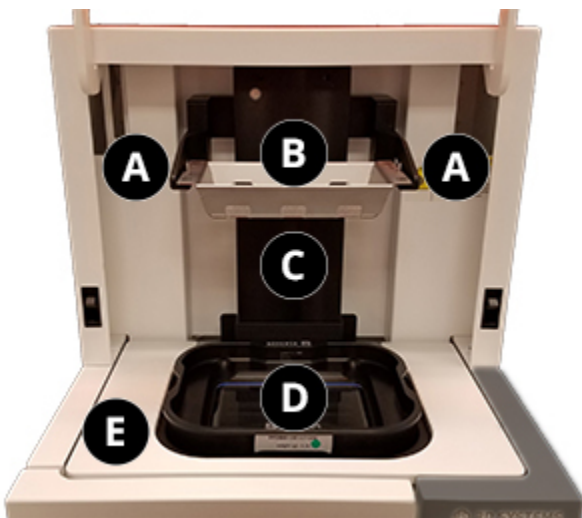

- A** Elevator Arms - Hold the print platform during part building
- B** Print Platform - The platform on which the printed part attaches during printing
- C** Elevator - The elevator moves the print platform up and down during a build. It also dictates the size of a printed part in the Z axis.
- D** Resin Tray - Holds the resin during the print process.
- E** Tension Arm - Lowering this onto the resin tray tensions the resin-tray film.

3.2 Figure 4 Standalone Lower Build Chamber

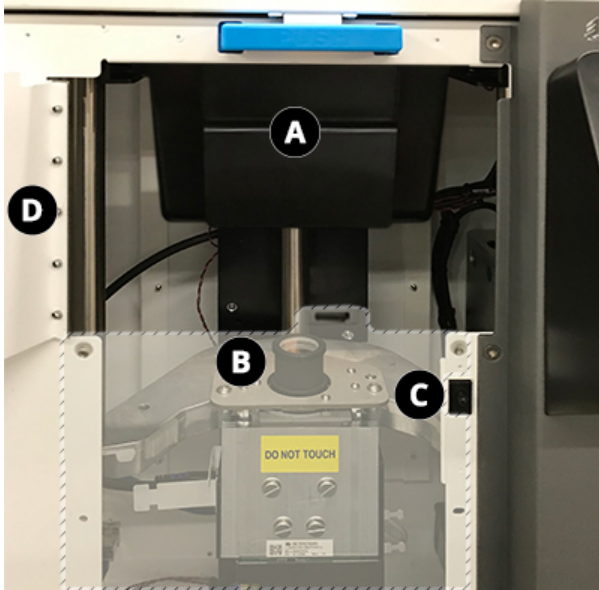

- A** Catch Tray - Catches resin that might spill over the resin tray, as well as resin that spills through the resin-tray membrane if it gets punctured.
- B** Projector Lens - Radiation is projected through this lens to the bottom layer of print material
- C** Door Closed Sensor - Senses whether or not the lower-chamber door is closed
- D** Catch Tray Access Door - Open this door to remove/replace the catch tray and to remove dust from the projector lens.



WARNING: THE OPERATOR DOES NOT HAVE ACCESS TO THE COMPONENTS OF THE LOWER CHAMBER BEYOND WHAT IS OUTLINED ON THIS PAGE. DO NOT REMOVE THE PLATE COVERING THIS CHAMBER. IT IS ONLY TO BE ACCESSED BY 3D SYSTEMS SERVICE PERSONNEL.

3.3 Figure 4 Standalone Touch Screen and QR-Code Scanner



- A** Touch Screen - used to control the actions of the printer and adjust printer settings
- B** QR-Code Scanner - used to scan QR codes on bottles of print material for use in the printer

3.4 Figure 4 Standalone Catch Tray



Catch tray, front

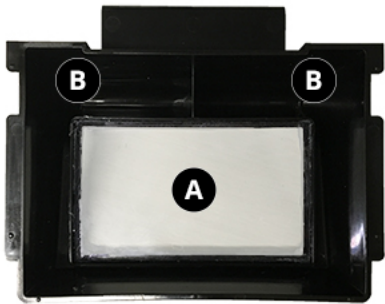

Catch tray, top

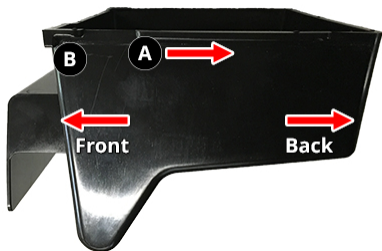

Catch tray, side

- A** Catch Tray - Protects the bottom of the print engine from print material spills. Please note that you will receive a new catch tray with each resin tray ordered.
- B** Catch-Tray Rails - Guide catch tray into position and hold it in place. There is a sensor on the right rail that ensures the catch tray is fully seated. If the catch tray is not fully seated, the printer will not allow you to print. If you are printing and the catch tray becomes unseated, this will abort the print job.

- A** Catch-Tray Glass - Allows UV radiation to pass through the catch tray to the bottom layer of print material.
- B** Collection Areas - The catch tray is designed such that any resin spilled over it will be channeled into these areas.

- A** Catch-Tray Rail Catch - Allows the catch tray to ride along the catch tray rails on the underside of the printer chassis
- B** Catch-Tray Slider Stop - This allows the catch tray to stop moving forward when the tray has reached its rear limit during installation.

3.5 Figure 4 Standalone Resin Tray

You will hand-pour resin into the resin tray before printing. The Figure 4 Standalone Printer works with the print materials listed in the section [Printer Materials and Properties](#) . The Figure 4 Standalone Printer comes with one resin tray per machine purchased. Purchasing multiple resin trays gives the user the ability to easily print with two different materials on one machine. The more resin trays you have, the more materials you can print with. If the resin tray is sufficiently cleaned in between builds, it is also possible to use a different print material in the same resin tray. However, not every resin can share the same tray, even if the resin tray is cleaned. Please see the section [Resin Tray Resin Cross-Usage](#) for more information. Determine the number of resin trays you will require.

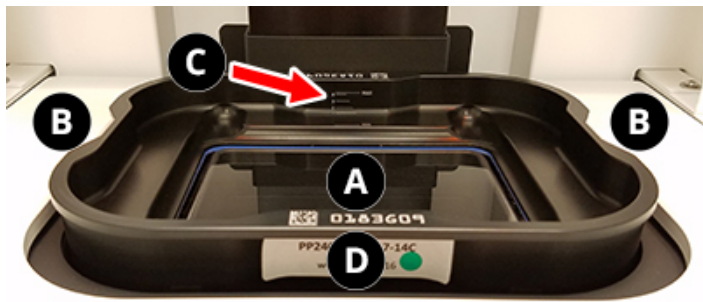

A

Transparent Membrane - This proprietary membrane creates a layer of oxygen in between the membrane and the bottom of the print material. This feature ensures that print material does not cure on the membrane under normal building conditions.

B

Tension Slots - The resin-tray tension arm fastens over these slots.

C

Material Fill Levels - These graduated markings represent four different levels to which you can fill the resin tray.

D

QR Code/Serial Number - The QR Code has the serial number embedded in its pattern. These give the resin tray a unique identification that can be read by a QR-code scanner.



Close up on material fill steps. Notice there is also an identical QR Code/Serial Number on the back of the tray.

3.5.1 Tension System

The resin-tray membrane must remain taut throughout the printing process. The Figure 4 Standalone achieves this with a tension arm that lowers down over the resin tray, as well as with two tension clips. This system also locks the resin tray in place during printing.

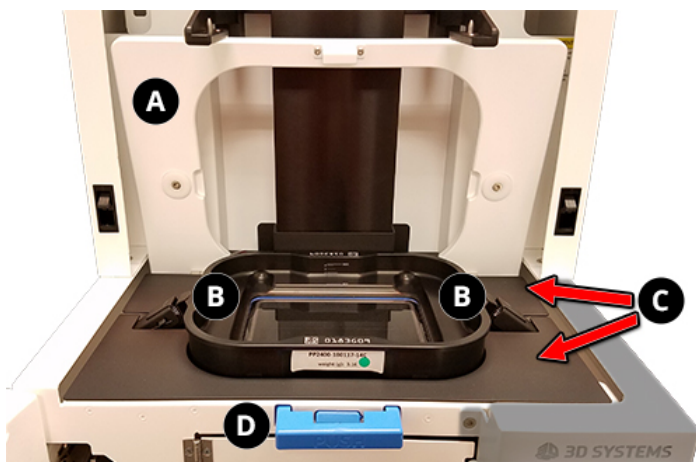

A

Tension Arm - pushes down the tension clamps and locks resin tray into place

B

Tension Clamps - spring-loaded mechanisms that tension the resin tray when engaged

C

Vanity Plates - these plates cover the printer chassis around the tension clamps

D

Tension-Arm Release Lever - Push this button in to release the tension arm and disengage the tension clamps.

3.5.2 Resin Tray Garage

The resin-tray garage can be used to store a resin tray with resin outside the machine, keeping UV light and contaminants out. The lid can also be used to cover the resin tray while in the machine.





Wear Protective Gloves: Due to the possibility of resin being on the resin-tray garage, wear 100% nitrile gloves whenever handling it, even if it appears clean.

3.6 Figure 4 Standalone Print Platform

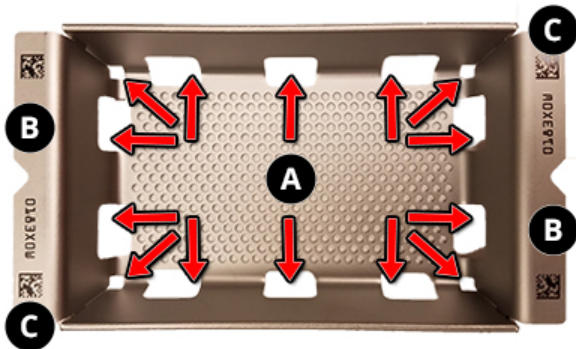

- A** Print Surface - Faces downward when printing. The printed part adheres to the holes in the print surface on the underside of the platform.
 - B** Elevator Guides - The flat surface of the guides stick to the magnetic surface of the print engine's elevator arms. The triangular grooves fit over the conical pins on the elevator arms.
 - C** QR Code/Serial Number - The QR Code has the serial number embedded in its pattern. These give the print platform a unique identification that can be read by a QR-code scanner.
-  Resin Drainage Holes - Prevent resin from settling on the top of the print platform

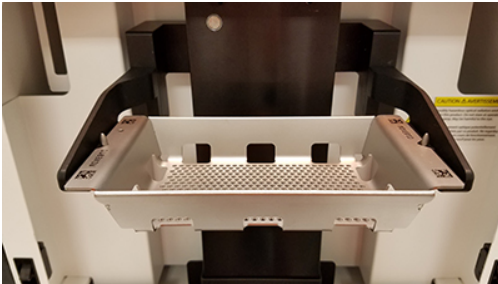

Print platform properly seated in the machine.

3.7 Figure 4 Standalone Back of Printer

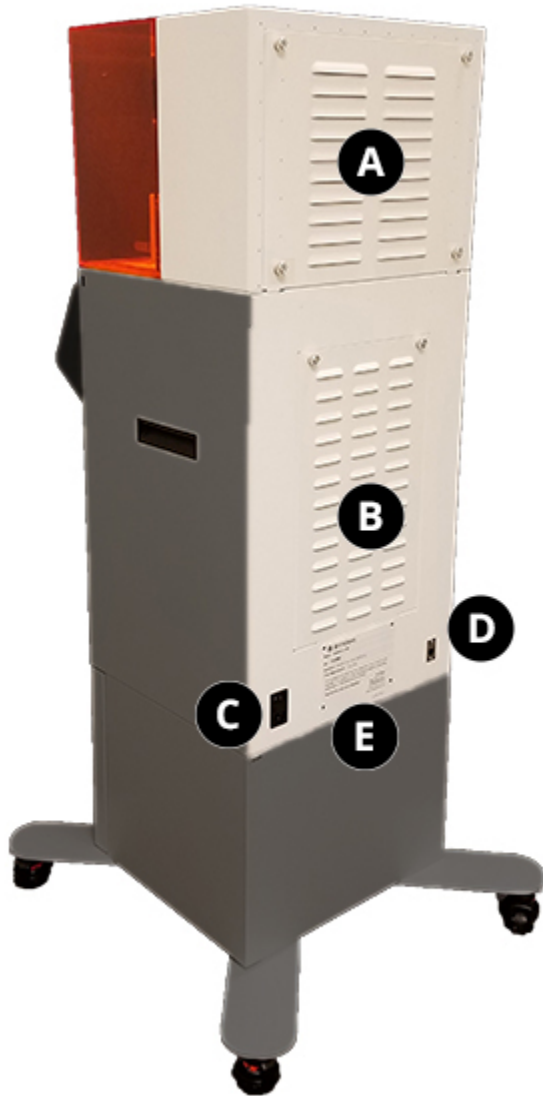

- A** Carbon Filter Bracket - Holds the carbon filter that minimizes fumes coming out of the printer
- B** Air Filter Bracket - Filters the air being pulled in by the cooling fan
- C** Power Inlet - Plug the female end of the printer's power cable into this inlet
- D** Ethernet Port - Plug the supplied Ethernet cable into this port
- E** Product Label - Provides system information for the printer

3.8 Figure 4 Standalone Pedestal

The printer comes with a pedestal in a separate package that serves several purposes:

1. Allows printer to roll for easy movement
2. Provides storage space under the printer for tools and supplies
3. Props the printer up to a level that provides maximum ease of use for the operator

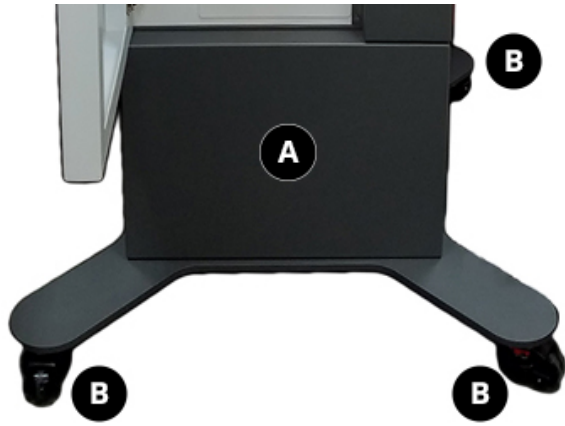

- A** Storage Compartment - used to hold tools and supplies for your printer.
- B** Casters/Leveling Feet - casters wheel the printer into place, while the leveling feet both level the printer and lock it into place. The fourth caster/foot cannot be seen in this photo.

3.9 Figure 4 Standalone Part Cleaning

After parts have finished building in the printer, it is necessary to clean them of any uncured resin according to the section [Cleaning Printed Parts](#) . You may choose a manual cleaning method or ultrasonic cleaning method, according to your needs.



Ultrasonic cleaner. This image is for sample purposes only and is not a recommendation or endorsement of any brand of ultrasonic cleaner.

3.10 Figure 4 Standalone Part Drying

After cleaning the part(s), it necessary to dry them of any solvent used in the cleaning step. This may be done in several ways, but a few recommended methods follow:

For all parts, be sure there is an absorbent cloth (disposable or otherwise) or container underneath the part to catch the solvent being cleaned off.

1. Shop air - if you have shop air in your facility, this would be the most-ideal way to air-dry the parts. This is not a replacement for air drying, but will speed up the process. Once finished using compressed air, let the part sit out for 30 minutes to air dry.



1. Air Compressor - If you do not have shop air, an air compressor would be the next-best solution. However, be aware that air compressors are fairly loud. This is not a replacement for air drying, but will speed up the process. Once finished using compressed air, let the part sit out for 30 minutes to air dry.



Air Compressor. This is for sample purposes only, and is not a recommendation or endorsement of any brand of air compressor.

1. Air Drying - Simply leave the part sitting on a paper towel for the time specified in the section [Dry the Build Parts](#) .

3.11 LC-3D Print Box

Sold separately from the printer, this is the post-curing oven that is recommended for use with the printer. Please see the complete User Guide that comes packaged with the LC-3DPrint Box for full usage instructions. For information on resin stirring times, please refer to the Resin Stirring and Curing Chart.



- A** Power Button - Switches machine on/off
- B** Front Panel - Graphical User Interface for oven. This shows information about the lamps, the time left for curing, and error messages.
- C** Oven Lid - Insert a printed part through this top opening. The lid has a safety interlock that stops the oven when the lid is open.
- D** Lamp Status Indicators - These indicators will turn red when the UV lamp pair needs to be changed. See the oven's Instructions for Use for more information.
- E** Timer - Shows time remaining in curing cycle
- F** Increasing Button - Increases operation time
- G** Decreasing Button - Decreases operation time
- H** Program Button - Toggles between preset operation times of 10, 20, and 30 minutes

- I** Start/Stop Button - Starts and stops oven operation
- J** UV Lamp - The oven comes with six 18W, 71-color lamps and six 18W, 78-color lamps. See the oven's Instructions for Use for information on correct orientation of lamps.
- K** Glass Plate - Holds the printed part during curing

LCD-3D Mixer

Before pouring the resin in the resin tray, it is necessary to mix it before each use to obtain the best-possible chemical mixture in the bottle. The recommended method of mixing the resin is with the NextDent LC-3DMixer. This device is sold separately from the printer. With this mixer, you can roll two bottles at once for a specified period of time. For information on resin stirring times, please refer to the Resin Stirring and Curing Chart.

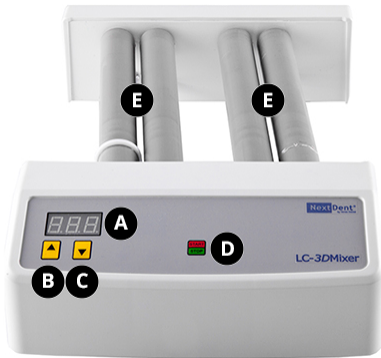

LC-3DMixer front



LC-3DMixer back



LC-3DMixer bottle placement

A	Mixing Timer - Shows the duration of resin mixing.
B	Time Increase - Increases the duration of mixing.
C	Time Decrease - Decreases the duration of mixing.
D	Start/Stop Button - Starts and stops bottle mixing.
E	Bottle Rollers - Rest the material bottles in between each of the pairs of rollers (please see the image below).
F	Power Button - Turns the mixer on and off.
G	Power Inlet - Plug the female end of the power cord into this inlet.
H	Device Label - Provides important information about the LC-3D Mixer.

4 FIGURE 4 STANDALONE SPECIFICATIONS AND REQUIREMENTS

Figure 4 Standalone Printer

Total Printer Footprint - without pedestal (xyz)	42.7 x 48.9 x 97.2 cm (16.8 x 19.3 x 38.3 in)
Total Printer Footprint - with pedestal (xyz)	64.4 x 66.8 x 136.3 cm (25.4 x 26.3 x 53.6 in)
Printer Weight	34.5 kg (76 lbs.)
Pedestal Weight	21.8 kg (48 lbs.)
Net Build Volume (xyz)	124 x 70 x 195 mm (4.88 x 2.76 x 7.67 in)
Native Resolution	65 micron (390.77 effective DPI)
Projector Wavelength	405 nm
Material Packaging	Opaque, non-reactive containers
Post-Processing	Separate part cleaner and UV oven
File Input to 3D Sprint	All 3D model file types
File Export to Printer	.f4x
Electrical Requirements	100-240VAC, 50-60Hz, 4.0A
Fuse Specifications	T5A/250V
Network Ready	Built-in Ethernet, must connect to internet

4.1 Figure 4 Standalone Printer Materials and Properties

The section below lists the print materials that are currently supported on the Figure 4 Standalone printer, as well as the properties of cured parts printed with these materials. Please note that not all properties in the table below apply to every material. For full technical specifications for your material, visit the [Figure 4 Standalone materials page](#) on 3dsystems.com, click the link for your material, and click the Tech Specs tab.



Note: All materials come in 1kg bottles.

4.1.1 Properties Figure 4 TOUGH CLEAR

METRIC	METHOD	VALUE
Color	N/A	Gray
Description	N/A	A clear, production-grade material engineered to offer long-term environmental UV, humidity stability, and clarity that avoids fading or discoloration for up to 8 years.
Speed (mm/hr) - 30 µm Print Mode/ Standard Build Style	Internal Method	Up to 17
Viscosity (cps @ 25C)	Brookfield viscometer	41
Liquid Density (g/cm ³)	Kruss K11 Force Tensiometer	1.21
Solid Density (g/cm ³)	ASTM D792	1.21
Tensile Strength Ultimate (MPa)	ASTM D638 (rigid)/D412(elastomer/ rubber)	50
Tensile Strength @ Yield (MPa)	ASTM D638	50

METRIC	METHOD	VALUE
Tensile Modulus (MPa)	ASTM D638 (rigid)/D412 (elastomer)	2200
Elongation at Yield (%)	ASTM D638	4.1
Elongation at Break (%)	ASTM D638 (rigid)/D412(elastomer)	13.1
Flex Strength (MPa)	ASTM D790	67
Flex Modulus (MPa)	ASTM D790	2000
Izod Notched Impact (J/m)	ASTM D256	18
Izod unnotched impact (J/m)	ASTM D4812	400
Tg (DMA, E")	ASTM E1640 (E"at 1°C/min)	48°C
HDT @ 0.455MPa/66PSI (C)	ASTM D648	48°C
HDT @ 1.82MPa/264 PSI (C)	ASTM D648	42°C
CTE above Tg ((µm/m)/°C)	ASTM E831	n/a
CTE below Tg ((µm/m)/°C)	ASTM E831	n/a

4.1.2 Properties Figure 4 JCAST-GRN 10

METRIC	METHOD	VALUE
Color	N/A	Gray
Description	N/A	Jewelry Casting
Speed (mm/hr) - 50 µm Print Mode/ Standard Build Style	Internal Method	Up to 8
Viscosity (cps @ 25C)	Brookfield viscometer	190
Liquid Density (g/cm3)	Kruss K11 Force Tensiometer	1.095
Solid Density (g/cm3)	ASTM D792	1.18
Tensile Strength Ultimate (MPa)	ASTM D638 (rigid)/D412(elastomer/ rubber)	13.7
Tensile Strength @ Yield (MPa)	ASTM D638	n/a
Tensile Modulus (MPa)	ASTM D638 (rigid)/D412 (elastomer)	262.4
Elongation at Yield (%)	ASTM D638	n/a
Elongation at Break (%)	ASTM D638 (rigid)/D412(elastomer)	12.1
Flex Strength (MPa)	ASTM D790	n/a
Flex Modulus (MPa)	ASTM D790	n/a
Izod Notched Impact (J/m)	ASTM D256	n/a
Izod unnotched impact (J/m)	ASTM D4812	n/a
Tg (DMA, E")	ASTM E1640 (E"at 1°C/min)	-1.3
HDT @ 66PSI (C)	ASTM D648	n/a
HDT @ 264 PSI (C)	ASTM D648	n/a
CTE above Tg ((µm/m)/°C)	ASTM E831	142.7
CTE below Tg ((µm/m)/°C)	ASTM E831	n/a

METRIC	METHOD	VALUE
Shore D Hardness	ASTM D2240	67.5
Shore A Hardness	ASTM D2240	n/a
24 Hour water absorption (%)	ASTM D570	1.3
Tear Strength (kN/m)	ASTM D624	n/a

4.1.3 Properties Figure 4 TOUGH GRY 10

METRIC	METHOD	VALUE
Color	N/A	Dark Gray
Description	N/A	Rigid, high-speed production material
Speed (mm/hr) - 50 µm Print Mode/ Standard Build Style	Internal Method	Up to 78
Viscosity (cps @ 25C)	Brookfield viscometer	493.8
Liquid Density (g/cm ³)	Kruss K11 Force Tensiometer	1.04
Solid Density (g/cm ³)	ASTM D792	1.11
Tensile Strength Ultimate (MPa)	ASTM D638 (rigid)/D412(elastomer/ rubber)	49.6
Tensile Strength @ Yield (MPa)	ASTM D638	49.6
Tensile Modulus (MPa)	ASTM D638 (rigid)/D412 (elastomer)	2184
Elongation at Yield (%)	ASTM D638	4
Elongation at Break (%)	ASTM D638 (rigid)/D412(elastomer)	25
Flex Strength (MPa)	ASTM D790	75.3
Flex Modulus (MPa)	ASTM D790	2069
Izod Notched Impact (J/m)	ASTM D256	29
Izod unnotched impact (J/m)	ASTM D4812	598
Tg (DMA, E")	ASTM E1640 (E"at 1°C/min)	57.9
HDT @ 66PSI (C)	ASTM D648	58.6
HDT @ 264 PSI (C)	ASTM D648	50.8
CTE above Tg ((µm/m)/°C)	ASTM E831	165
CTE below Tg ((µm/m)/°C)	ASTM E831	93
Shore D Hardness	ASTM D2240	81.3
Shore A Hardness	ASTM D2240	n/a
24 Hour water absorption (%)	ASTM D570	0.34
Tear Strength (kN/m)	ASTM D624	n/a

4.1.4 Properties Figure 4 TOUGH GRY 15

METRIC	METHOD	VALUE
Color	N/A	Gray

METRIC	METHOD	VALUE
Description	N/A	Rigid production material
Speed (mm/hr) - 50 µm Print Mode/ Standard Build Style	Internal Method	up to 41
Viscosity (cps @ 25C)	Brookfield viscometer	779
Liquid Density (g/cm ³)	Kruss K11 Force Tensiometer	1.04
Solid Density (g/cm ³)	ASTM D792	1.12
Tensile Strength Ultimate (MPa)	ASTM D638 (rigid)/D412(elastomer/ rubber)	48.4
Tensile Strength @ Yield (MPa)	ASTM D638	48.3
Tensile Modulus (MPa)	ASTM D638 (rigid)/D412 (elastomer)	2117
Elongation at Yield (%)	ASTM D638	4
Elongation at Break (%)	ASTM D638 (rigid)/D412(elastomer)	35
Flex Strength (MPa)	ASTM D790	73
Flex Modulus (MPa)	ASTM D790	1961
Izod Notched Impact (J/m)	ASTM D256	32
Izod unnotched impact (J/m)	ASTM D4812	599
599Tg (DMA, E'')	ASTM E1640 (E''at 1°C/min)	54.6
HDT @ 66PSI (C)	ASTM D648	58.8
HDT @ 264 PSI (C)	ASTM D648	51.4
CTE above Tg ((µm/m)/°C)	ASTM E831	158
CTE below Tg ((µm/m)/°C)	ASTM E831	96
Shore D Hardness	ASTM D2240	81.6
Shore A Hardness	ASTM D2240	n/a
24 Hour water absorption (%)	ASTM D570	0.37
Tear Strength (kN/m)	ASTM D624	n/a

4.1.5 Figure 4 EGGHELL-AMB 10

METRIC	METHOD	VALUE
Color	N/A	Amber
Description	N/A	Rigid plastic used to create sacrificial tooling that withstands silicone injection at high temperature and pressure, but breaks away easily
Speed (mm/hr) - 50 µm Print Mode/ Standard Build Style	Internal Method	Up to 43
Viscosity (cps @ 25C)	Brookfield viscometer	212
Liquid Density (g/cm ³)	Kruss K11 Force Tensiometer	1.08
Solid Density (g/cm ³)	ASTM D792	1.16

METRIC	METHOD	VALUE
Tensile Strength Ultimate (MPa)	ASTM D638 (rigid)/D412(elastomer/ rubber)	72
Tensile Strength @ Yield (MPa)	ASTM D638	n/a
Tensile Modulus (MPa)	ASTM D638 (rigid)/D412 (elastomer)	2765
Elongation at Yield (%)	ASTM D638	n/a
Elongation at Break (%)	ASTM D638 (rigid)/D412(elastomer)	5
Flex Strength (MPa)	ASTM D790	114
Flex Modulus (MPa)	ASTM D790	2890
Izod Notched Impact (J/m)	ASTM D256	15
Izod unnotched impact (J/m)	ASTM D4812	138
Tg (DMA, E")	ASTM E1640 (E"at 1°C/min)	83
HDT @ 66PSI (C)	ASTM D648	89
HDT @ 264 PSI (C)	ASTM D648	72
CTE above Tg ((µm/m)/°C)	ASTM E831	n/a
CTE below Tg ((µm/m)/°C)	ASTM E831	n/a
Shore D Hardness	ASTM D2240	85
Shore A Hardness	ASTM D2240	n/a
24 Hour water absorption (%)	ASTM D570	0.27
Tear Strength (kN/m)	ASTM D624	n/a

4.1.6 Properties Figure 4 ELAST-BLK 10

METRIC	METHOD	VALUE
Color	N/A	Black
Description	N/A	Design Elastomeric
Speed (mm/hr) - 50 µm Print Mode/ Standard Build Style	Internal Method	Up to 47
Viscosity (cps @ 25C)	Brookfield viscometer	1201
Liquid Density (g/cm3)	Kruss K11 Force Tensiometer	1.06
Solid Density (g/cm3)	ASTM D792	1.13
Tensile Strength Ultimate (MPa)	ASTM D638 (rigid)/D412(elastomer/ rubber)	3.6
Tensile Strength @ Yield (MPa)	ASTM D638	n/a
Tensile Modulus (MPa)	ASTM D638 (rigid)/D412 (elastomer)	3.6
Elongation at Yield (%)	ASTM D638	n/a
Elongation at Break (%)	ASTM D638 (rigid)/D412(elastomer)	83
Flex Strength (MPa)	ASTM D790	n/a
Flex Modulus (MPa)	ASTM D790	n/a
Izod Notched Impact (J/m)	ASTM D256	n/a

METRIC	METHOD	VALUE
Izod unnotched impact (J/m)	ASTM D4812	n/a
Tg (DMA, E'')	ASTM E1640 (E''at 1°C/min)	-26.2
HDT @ 66PSI (C)	ASTM D648	n/a
HDT @ 264 PSI (C)	ASTM D648	n/a
CTE above Tg (($\mu\text{m}/\text{m}$)/°C)	ASTM E831	n/a
CTE below Tg (($\mu\text{m}/\text{m}$)/°C)	ASTM E831	n/a
Shore D Hardness	ASTM D2240	n/a
Shore A Hardness	ASTM D2240	64.7
24 Hour water absorption (%)	ASTM D570	1.4
Tear Strength (kN/m)	ASTM D624	11.2

4.1.7 Properties Figure 4 FLEX-BLK 10

METRIC SPECIAL CONSIDERATIONS FOR FLEX-BLK 10	METHOD	VALUE
Color	N/A	Black
Description	N/A	Polypropylene-like, flexible
Speed (mm/hr) - 50 μm Print Mode/ Standard Build Style	Internal Method	Up to 30
Viscosity (cps @ 25C)	Brookfield viscometer	2108
Liquid Density (g/cm ³)	Kruss K11 Force Tensiometer	1.06
Solid Density (g/cm ³)	ASTM D792	1.15
Tensile Strength Ultimate (MPa)	ASTM D638 (rigid)/D412(elastomer/ rubber)	46
Tensile Strength @ Yield (MPa)	ASTM D638	37
Tensile Modulus (MPa)	ASTM D638 (rigid)/D412 (elastomer)	1402
Elongation at Yield (%)	ASTM D638	6
Elongation at Break (%)	ASTM D638 (rigid)/D412(elastomer)	104
Flex Strength (MPa)	ASTM D790	37
Flex Modulus (MPa)	ASTM D790	986
Izod Notched Impact (J/m)	ASTM D256	55
Izod unnotched impact (J/m)	ASTM D4812	Did not break
Tg (DMA, E'')	ASTM E1640 (E''at 1°C/min)	17.8
HDT @ 66PSI (C)	ASTM D648	52
HDT @ 264 PSI (C)	ASTM D648	43
CTE above Tg (($\mu\text{m}/\text{m}$)/°C)	ASTM E831	91
CTE below Tg (($\mu\text{m}/\text{m}$)/°C)	ASTM E831	138
Shore D Hardness	ASTM D2240	76.2

METRIC SPECIAL CONSIDERATIONS FOR FLEX-BLK 10	METHOD	VALUE
Shore A Hardness	ASTM D2240	n/a
24 Hour water absorption (%)	ASTM D570	1.4
Tear Strength (kN/m)	ASTM D624	n/a

4.1.8 Special Considerations for FLEX BLK 10

Figure 4 FLEX-BLK 10 printed-part mechanical properties will change when exposed to low and high temperature and/or humidity. Parts will become either softer or tougher as temperatures increase/decrease beyond typical office environments. Similarly, impact strength will drop as temperature and humidity are decreased outside of typical office environments. In use cases where stable printed-part mechanical properties are important, FLEX-BLK 10 is recommended for indoor use, at temperatures between 10-30°C (50-86°F), and 10-65% relative humidity. The best conditions are around 20°C (68°F) and 40-50% RH (non-condensing). The printed-part mechanical properties most-susceptible to change are: notch impact strength, tensile modulus and yield strength. Please refer to the charts below for detailed information on printed-part mechanical properties as a function of temperature and relative humidity.



Note: The printed-part mechanical properties will return to standard when parts dry completely (back into the 10-65% RH range) and are at standard room temperature. In the case of the effects of exposure to high humidity, return to standard properties could take a day or two.

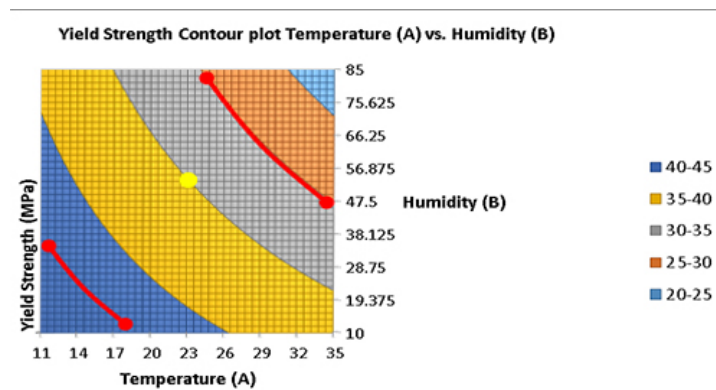

Temperature - °C, Humidity - %RH

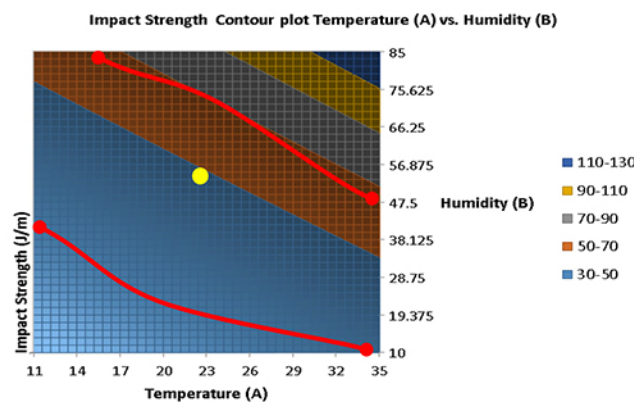

Temperature - °C, Humidity - %RH

4.1.9 Properties Figure 4 FLEX-BLK 20

Figure 4 FLEX-BLK 20

METRIC	METHOD	VALUE
Color	N/A	Black

METRIC	METHOD	VALUE
Description	N/A	Flexible, high impact-resistant material for extremely durable black parts, with the look and feel of production polypropylene.
Speed (mm/hr) - 50 µm Print Mode/ Standard Build Style	Internal Method	Up to 25
Viscosity (cps @ 25C)	Brookfield viscometer	2250
Liquid Density (g/cm3)	Kruss K11 Force Tensiometer	1.11
Solid Density (g/cm3)	ASTM D792	1.18
Tensile Strength Ultimate (MPa)	ASTM D638 (rigid)/D412(elastomer/ rubber)	36
Tensile Strength @ Yield (MPa)	ASTM D638	24
Tensile Modulus (MPa)	ASTM D638 (rigid)/D412 (elastomer)	840
Elongation at Yield (%)	ASTM D638	7.5
Elongation at Break (%)	ASTM D638 (rigid)/D412(elastomer)	86
Flex Strength (MPa)	ASTM D790	22
Flex Modulus (MPa)	ASTM D790	680
Izod Notched Impact (J/m)	ASTM D256	91
Izod unnotched impact (J/m)	ASTM D4812	Did not break
Tg (DMA, E")	ASTM E1640 (E"at 1°C/min)	11
HDT @ 66PSI (C)	ASTM D648	41
HDT @ 264 PSI (C)	ASTM D648	<25
CTE above Tg ((µm/m)/°C)	ASTM E831	188
CTE below Tg ((µm/m)/°C)	ASTM E831	69
Shore D Hardness	ASTM D2240	68
Shore A Hardness	ASTM D2240	n/a
24 Hour water absorption (%)	ASTM D570	0.64
Tear Strength (kN/m)	ASTM D624	n/a

4.1.10 Properties Figure 4 HI TEMP 300-AMB

METRIC	METHOD	VALUE
Color	N/A	Amber
Description	N/A	Industry-leading, ultra-high-temperature-resistant (HDT > 300°C), rigid plastic suitable for the harshest environments
Speed (mm/hr) - 50 µm Print Mode/ Standard Build Style	Internal Method	Up to 36
Viscosity (cps @ 25C)	Brookfield viscometer	1725
Liquid Density (g/cm3)	Kruss K11 Force Tensiometer	1.19

METRIC	METHOD	VALUE
Solid Density (g/cm ³)	ASTM D792	1.3
Tensile Strength Ultimate (MPa)	ASTM D638 (rigid)/D412(elastomer/ rubber)	81
Tensile Strength @ Yield (MPa)	ASTM D638	n/a
Tensile Modulus (MPa)	ASTM D638 (rigid)/D412 (elastomer)	4000
Elongation at Yield (%)	ASTM D638	n/a
Elongation at Break (%)	ASTM D638 (rigid)/D412(elastomer)	2.6
Flex Strength (MPa)	ASTM D790	140
Flex Modulus (MPa)	ASTM D790	4260
Izod Notched Impact (J/m)	ASTM D256	10
Izod unnotched impact (J/m)	ASTM D4812	138
Tg (DMA, E'')	ASTM E1640 (E''at 1°C/min)	n/a
HDT @ 66PSI (C)	ASTM D648	>300
HDT @ 264 PSI (C)	ASTM D648	>300
CTE above Tg ((μm/m)/°C)	ASTM E831	54
CTE below Tg ((μm/m)/°C)	ASTM E831	62
Shore D Hardness	ASTM D2240	89
Shore A Hardness	ASTM D2240	n/a
24 Hour water absorption (%)	ASTM D570	0.36
Tear Strength (kN/m)	ASTM D624	n/a

4.1.11 Properties Figure 4 High Temp 150C FR Black

METRIC	METHOD	VALUE
Color	N/A	Black
Description	N/A	A rigid, fire-retardant resin that can be used for production of parts requiring UL 94 V0 capability as well as FAR Part 23.853 and FAR 25.853 capability
Speed (mm/hr) - 50 μm Print Mode/ Standard Build Style	Internal Method	Up to 36
Viscosity (cps @ 25C)	Brookfield viscometer	1700
Liquid Density (g/cm ³)	Kruss K11 Force Tensiometer	1.2
Solid Density (g/cm ³)	ASTM D792	1.29
Tensile Strength Ultimate (MPa)	ASTM D638 (rigid)/D412(elastomer/ rubber)	58
Tensile Strength @ Yield (MPa)	ASTM D638	n/a
Tensile Modulus (MPa)	ASTM D638 (rigid)/D412 (elastomer)	2600
Elongation at Yield (%)	ASTM D638	n/a
Elongation at Break (%)	ASTM D638 (rigid)/D412(elastomer)	4

METRIC	METHOD	VALUE
Flex Strength (MPa)	ASTM D790	100
Flex Modulus (MPa)	ASTM D790	2900
Izod Notched Impact (J/m)	ASTM D256	10
Izod unnotched impact (J/m)	ASTM D4812	50
Tg (DMA, E")	ASTM E1640 (E"at 1°C/min)	n/a
HDT @ 66PSI (C)	ASTM D648	>150
HDT @ 264 PSI (C)	ASTM D648	89
CTE above Tg ((µm/m)/°C)	ASTM E831	158
CTE below Tg ((µm/m)/°C)	ASTM E831	98
Shore D Hardness	ASTM D2240	85
Shore A Hardness	ASTM D2240	n/a
24 Hour water absorption (%)	ASTM D570	0.26
Tear Strength (kN/m)	ASTM D624	n/a

4.1.12 Properties Figure 4 JEWEL MASTER GRY

Figure 4 JEWEL MASTER GRY

METRIC	METHOD	VALUE
Color	N/A	Gray
Description	N/A	A versatile, high HDT master pattern material for jewelry silicone molds and high-visualization detailed prototypes of complex and fine designs.
Speed (mm/hr) - 50 µm Print Mode/ Standard Build Style	Internal Method	Up to 14
Viscosity (cps @ 25C)	Brookfield viscometer	2147
Liquid Density (g/cm3)	Kruss K11 Force Tensiometer	1.19
Solid Density (g/cm3)	ASTM D792	1.29
Tensile Strength Ultimate (MPa)	ASTM D638 (rigid)/D412(elastomer/ rubber)	67
Tensile Strength @ Yield (MPa)	ASTM D638	n/a
Tensile Modulus (MPa)	ASTM D638 (rigid)/D412 (elastomer)	3548
Elongation at Yield (%)	ASTM D638	n/a
Elongation at Break (%)	ASTM D638 (rigid)/D412(elastomer)	2.5
Flex Strength (MPa)	ASTM D790	129
Flex Modulus (MPa)	ASTM D790	3980
Izod Notched Impact (J/m)	ASTM D256	n/a
Izod unnotched impact (J/m)	ASTM D4812	n/a
Tg (DMA, E")	ASTM E1640 (E"at 1°C/min)	n/a
HDT @ 66PSI (C)	ASTM D648	>300

METRIC	METHOD	VALUE
HDT @ 264 PSI (C)	ASTM D648	111
CTE above Tg (($\mu\text{m}/\text{m}$)/ $^{\circ}\text{C}$)	ASTM E831	146
CTE below Tg (($\mu\text{m}/\text{m}$)/ $^{\circ}\text{C}$)	ASTM E831	80
Shore D Hardness	ASTM D2240	88
Shore A Hardness	ASTM D2240	n/a
24 Hour water absorption (%)	ASTM D570	n/a
Tear Strength (kN/m)	ASTM D624	n/a

4.1.13 Properties Figure 4 MED-AMB 10

METRIC	METHOD	VALUE
Color	N/A	Amber
Description	N/A	Translucent, Rigid Material with biocompatibility, designed to support a range of industrial and medical applications. For biocompatibility information, please visit here .
Speed (mm/hr) - 50 μm Print Mode/ Standard Build Style	Internal Method	up to 43
Viscosity (cps @ 25C)	Brookfield viscometer	1138
Liquid Density (g/cm ³)	Kruss K11 Force Tensiometer	1.12
Solid Density (g/cm ³)	ASTM D792	1.20
Tensile Strength Ultimate (MPa)	ASTM D638 (rigid)/D412(elastomer/ rubber)	69
Tensile Strength @ Yield (MPa)	ASTM D638	n/a
Tensile Modulus (MPa)	ASTM D638 (rigid)/D412 (elastomer)	2760
Elongation at Yield (%)	ASTM D638	n/a
Elongation at Break (%)	ASTM D638 (rigid)/D412(elastomer)	4
Flex Strength (MPa)	ASTM D790	111
Flex Modulus (MPa)	ASTM D790	2809
Izod Notched Impact (J/m)	ASTM D256	18
Izod unnotched impact (J/m)	ASTM D4812	220
Tg (DMA, E")	ASTM E1640 (E"at 1 $^{\circ}\text{C}/\text{min}$)	109.6
HDT @ 66PSI (C)	ASTM D648	118.6
HDT @ 264 PSI (C)	ASTM D648	93.6
CTE above Tg (($\mu\text{m}/\text{m}$)/ $^{\circ}\text{C}$)	ASTM E831	177
CTE below Tg (($\mu\text{m}/\text{m}$)/ $^{\circ}\text{C}$)	ASTM E831	84
Shore D Hardness	ASTM D2240	83.5
Shore A Hardness	ASTM D2240	n/a
24 Hour water absorption (%)	ASTM D570	0.26

METRIC	METHOD	VALUE
Tear Strength (kN/m)	ASTM D624	n/a

4.1.14 Properties Figure 4 MED-WHT 10

METRIC	METHOD	VALUE
Color	N/A	Ivory
Description	N/A	White, Rigid Material with biocompatibility, designed to support a range of industrial and medical applications. For biocompatibility information, please visit here .
Speed (mm/hr) - 50 µm Print Mode/ Standard Build Style	Internal Method	Up to 41
Viscosity (cps @ 25C)	Brookfield viscometer	937
Liquid Density (g/cm3)	Kruss K11 Force Tensiometer	1.18
Solid Density (g/cm3)	ASTM D792	1.27
Tensile Strength Ultimate (MPa)	ASTM D638 (rigid)/D412(elastomer/ rubber)	60
Tensile Strength @ Yield (MPa)	ASTM D638	n/a
Tensile Modulus (MPa)	ASTM D638 (rigid)/D412 (elastomer)	3090
Elongation at Yield (%)	ASTM D638	n/a
Elongation at Break (%)	ASTM D638 (rigid)/D412(elastomer)	3
Flex Strength (MPa)	ASTM D790	112
Flex Modulus (MPa)	ASTM D790	3290
Izod Notched Impact (J/m)	ASTM D256	17
Izod unnotched impact (J/m)	ASTM D4812	91
Tg (DMA, E")	ASTM E1640 (E"at 1°C/min)	102.4
HDT @ 66PSI (C)	ASTM D648	102.0
HDT @ 264 PSI (C)	ASTM D648	79.4
CTE above Tg ((µm/m)/°C)	ASTM E831	154
CTE below Tg ((µm/m)/°C)	ASTM E831	83
Shore D Hardness	ASTM D2240	84.1
Shore A Hardness	ASTM D2240	n/a
24 Hour water absorption (%)	ASTM D570	0.25
Tear Strength (kN/m)	ASTM D624	n/a

4.1.15 Properties Figure 4 PRO-BLK 10

Figure 4 PRO-BLK 10

METRIC	METHOD	VALUE
Color	N/A	Black

METRIC	METHOD	VALUE
Description	N/A	Production-grade additive manufacturing material with game-changing thermoplastic-like mechanical properties, and environmental stability of mechanical and performance properties over time.
Speed (mm/hr) - 50 µm Print Mode/ Standard Build Style	Internal Method	Up to 62
Viscosity (cps @ 25C)	Brookfield viscometer	293
Liquid Density (g/cm ³)	Kruss K11 Force Tensiometer	1.07
Solid Density (g/cm ³)	ASTM D792	1.16
Tensile Strength Ultimate (MPa)	ASTM D638 (rigid)/D412(elastomer/ rubber)	63
Tensile Strength @ Yield (MPa)	ASTM D638	63
Tensile Modulus (MPa)	ASTM D638 (rigid)/D412 (elastomer)	2320
Elongation at Yield (%)	ASTM D638	4.7
Elongation at Break (%)	ASTM D638 (rigid)/D412(elastomer)	12
Flex Strength (MPa)	ASTM D790	92
Flex Modulus (MPa)	ASTM D790	2290
Izod Notched Impact (J/m)	ASTM D256	24
Izod unnotched impact (J/m)	ASTM D4812	614
Tg (DMA, E")	ASTM E1640 (E"at 1°C/min)	62
HDT @ 66PSI (C)	ASTM D648	70
HDT @ 264 PSI (C)	ASTM D648	56
CTE above Tg ((µm/m)/°C)	ASTM E831	188
CTE below Tg ((µm/m)/°C)	ASTM E831	71
Shore D Hardness	ASTM D2240	79
Shore A Hardness	ASTM D2240	n/a
24 Hour water absorption (%)	ASTM D570	1.16
Tear Strength (kN/m)	ASTM D624	n/a

4.1.16 Properties Figure 4 Rigid 140C Black

METRIC	METHOD	VALUE
Color	N/A	Black

METRIC	METHOD	VALUE
Description	N/A	A high performance material, delivering production-grade parts with long-term mechanical stability in various environments. Suitable for housings, casings, and all types of prototyping or production components. Ideal for automotive under-the-hood and internal cabin end-use clips, covers, connectors, housings & fasteners, electrical latching, and board connectors.
Speed (mm/hr) - 50 µm Print Mode/ Standard Build Style	Internal Method	Up to 25
Viscosity (cps @ 25C)	Brookfield viscometer	900
Liquid Density (g/cm ³)	Kruss K11 Force Tensiometer	1.16
Solid Density (g/cm ³)	ASTM D792	1.19
Tensile Strength Ultimate (MPa)	ASTM D638 (rigid)/D412(elastomer/ rubber)	80
Tensile Strength @ Yield (MPa)	ASTM D638	n/a
Tensile Modulus (MPa)	ASTM D638 (rigid)/D412 (elastomer)	2800
Elongation at Yield (%)	ASTM D638	n/a
Elongation at Break (%)	ASTM D638 (rigid)/D412(elastomer)	5.6
Flex Strength (MPa)	ASTM D790	110
Flex Modulus (MPa)	ASTM D790	2700
Izod Notched Impact (J/m)	ASTM D256	16
Izod unnotched impact (J/m)	ASTM D4812	330
Tg (DMA, E")	ASTM E1640 (E"at 1°C/min)	124
HDT @ 66PSI (C)	ASTM D648	140
HDT @ 264 PSI (C)	ASTM D648	124
CTE above Tg ((µm/m)/°C)	ASTM E831	110
CTE below Tg ((µm/m)/°C)	ASTM E831	89
Shore D Hardness	ASTM D2240	84
Shore A Hardness	ASTM D2240	n/a
24 Hour water absorption (%)	ASTM D570	1.54
Tear Strength (kN/m)	ASTM D624	n/a

4.1.17 Properties Figure 4 Rigid Gray

METRIC	METHOD	VALUE
Color	N/A	Gray
Description	N/A	The balance of thermal and mechanical properties, combined with excellent print quality and long-term Indoor and outdoor stability for prototyping and production.

METRIC	METHOD	VALUE
Speed (mm/hr) - 50 µm Print Mode/ Standard Build Style	Internal Method	Up to 48
Viscosity (cps @ 25C)	Brookfield viscometer	300
Liquid Density (g/cm ³)	Kruss K11 Force Tensiometer	1.07
Solid Density (g/cm ³)	ASTM D792	1.15
Tensile Strength Ultimate (MPa)	ASTM D638 (rigid)/D412(elastomer/ rubber)	61
Tensile Strength @ Yield (MPa)	ASTM D638	61
Tensile Modulus (MPa)	ASTM D638 (rigid)/D412 (elastomer)	2400
Elongation at Yield (%)	ASTM D638	4.6
Elongation at Break (%)	ASTM D638 (rigid)/D412(elastomer)	30
Flex Strength (MPa)	ASTM D790	87
Flex Modulus (MPa)	ASTM D790	2200
Izod Notched Impact (J/m)	ASTM D256	21
Izod unnotched impact (J/m)	ASTM D4812	150
Tg (DMA, E")	ASTM E1640 (E"at 1°C/min)	60
HDT @ 66PSI (C)	ASTM D648	72
HDT @ 264 PSI (C)	ASTM D648	59
CTE above Tg ((µm/m)/°C)	ASTM E831	166
CTE below Tg ((µm/m)/°C)	ASTM E831	81
Shore D Hardness	ASTM D2240	82
Shore A Hardness	ASTM D2240	n/a
24 Hour water absorption (%)	ASTM D570	0.99
Tear Strength (kN/m)	ASTM D624	n/a

4.1.18 Properties Figure 4 Rigid White

METRIC	METHOD	VALUE
Color	N/A	White
Description	N/A	Opaque rigid white production-grade plastic for same-day parts. This biocompatible-capable material provides a smooth surface finish, long-term environmental stability, and long-lasting, clean white color.
Speed (mm/hr) - 50 µm Print Mode/ Standard Build Style	Internal Method	Up to 47
Viscosity (cps @ 25C)	Brookfield viscometer	270
Liquid Density (g/cm ³)	Kruss K11 Force Tensiometer	1.09
Solid Density (g/cm ³)	ASTM D792	1.16

METRIC	METHOD	VALUE
Tensile Strength Ultimate (MPa)	ASTM D638 (rigid)/D412(elastomer/ rubber)	57
Tensile Strength @ Yield (MPa)	ASTM D638	57
Tensile Modulus (MPa)	ASTM D638 (rigid)/D412 (elastomer)	2100
Elongation at Yield (%)	ASTM D638	4.5
Elongation at Break (%)	ASTM D638 (rigid)/D412(elastomer)	20
Flex Strength (MPa)	ASTM D790	84
Flex Modulus (MPa)	ASTM D790	2200
Izod Notched Impact (J/m)	ASTM D256	21
Izod unnotched impact (J/m)	ASTM D4812	160
Tg (DMA, E")	ASTM E1640 (E"at 1°C/min)	64
HDT @ 66PSI (C)	ASTM D648	65
HDT @ 264 PSI (C)	ASTM D648	55
CTE above Tg ((µm/m)/°C)	ASTM E831	146
CTE below Tg ((µm/m)/°C)	ASTM E831	82
Shore D Hardness	ASTM D2240	81
Shore A Hardness	ASTM D2240	n/a
24 Hour water absorption (%)	ASTM D570	1.88
Tear Strength (kN/m)	ASTM D624	n/a

4.1.19 Properties Figure 4 RUBBER-65A BLK

METRIC	METHOD	VALUE
Color	N/A	Black
Description	N/A	A mid-tear strength, production-grade rubber combined with Shore 65A hardness and a high elongation at break
Speed (mm/hr) - 50 µm Print Mode/ Standard Build Style	Internal Method	Up to 15
Viscosity (cps @ 25C)	Brookfield viscometer	240
Liquid Density (g/cm3)	Kruss K11 Force Tensiometer	1.03
Solid Density (g/cm3)	ASTM D792	1.12
Tensile Strength Ultimate (MPa)	ASTM D638 (rigid)/D412(elastomer/ rubber)	5
Tensile Strength @ Yield (MPa)	ASTM D638	n/a
Tensile Modulus (MPa)	ASTM D638 (rigid)/D412 (elastomer)	23
Elongation at Yield (%)	ASTM D638	n/a
Elongation at Break (%)	ASTM D638 (rigid)/D412(elastomer)	126
Flex Strength (MPa)	ASTM D790	n/a
Flex Modulus (MPa)	ASTM D790	n/a

METRIC	METHOD	VALUE
Izod Notched Impact (J/m)	ASTM D256	n/a
Izod unnotched impact (J/m)	ASTM D4812	n/a
Tg (DMA, E")	ASTM E1640 (E"at 1°C/min)	-10
HDT @ 66PSI (C)	ASTM D648	n/a
HDT @ 264 PSI (C)	ASTM D648	n/a
CTE above Tg ((µm/m)/°C)	ASTM E831	184
CTE below Tg ((µm/m)/°C)	ASTM E831	84
Shore D Hardness	ASTM D2240	n/a
Shore A Hardness	ASTM D2240	65
24 Hour water absorption (%)	ASTM D570	2.6
Tear Strength (kN/m)	ASTM D624	1.8

4.1.20 Properties Figure 4 RUBBER-BLK 10

Figure 4 RUBBER-BLK 10

METRIC	METHOD	VALUE
Color	N/A	Black
Description	N/A	High-tear-strength material for production-hard, rubber-like parts with slow-rebound.
Speed (mm/hr) - 50 µm Print Mode/ Standard Build Style	Internal Method	Up to 26
Viscosity (cps @ 25C)	Brookfield viscometer	1413
Liquid Density (g/cm3)	Kruss K11 Force Tensiometer	1.11
Solid Density (g/cm3)	ASTM D792	1.17
Tensile Strength Ultimate (MPa)	ASTM D638 (rigid)/D412(elastomer/ rubber)	19
Tensile Strength @ Yield (MPa)	ASTM D638	n/a
Tensile Modulus (MPa)	ASTM D638 (rigid)/D412 (elastomer)	434
Elongation at Yield (%)	ASTM D638	n/a
Elongation at Break (%)	ASTM D638 (rigid)/D412(elastomer)	75
Flex Strength (MPa)	ASTM D790	n/a
Flex Modulus (MPa)	ASTM D790	n/a
Izod Notched Impact (J/m)	ASTM D256	128
Izod unnotched impact (J/m)	ASTM D4812	Did not break
Tg (DMA, E")	ASTM E1640 (E"at 1°C/min)	21
HDT @ 66PSI (C)	ASTM D648	n/a
HDT @ 264 PSI (C)	ASTM D648	n/a
CTE above Tg ((µm/m)/°C)	ASTM E831	n/a
CTE below Tg ((µm/m)/°C)	ASTM E831	n/a

METRIC	METHOD	VALUE
Shore D Hardness	ASTM D2240	59
Shore A Hardness	ASTM D2240	97
24 Hour water absorption (%)	ASTM D570	0.4
Tear Strength (kN/m)	ASTM D624	76

4.1.21 Properties Figure 4 Tough 60C White

Figure 4 Tough 60C White

METRIC	METHOD	VALUE
Color	N/A	White
Description	N/A	Versatile utilities with a good combination of impact strength, elongation, and tensile strength. Long-term indoor and outdoor mechanical and color stability.
Speed (mm/hr) - 50 µm Print Mode/ Standard Build Style	Internal Method	Up to 24
Viscosity (cps @ 25C)	Brookfield viscometer	1800
Liquid Density (g/cm ³)	Kruss K11 Force Tensiometer	1.15
Solid Density (g/cm ³)	ASTM D792	1.23
Tensile Strength Ultimate (MPa)	ASTM D638 (rigid)/D412(elastomer/ rubber)	35
Tensile Strength @ Yield (MPa)	ASTM D638	35
Tensile Modulus (MPa)	ASTM D638 (rigid)/D412 (elastomer)	1500
Elongation at Yield (%)	ASTM D638	7.1
Elongation at Break (%)	ASTM D638 (rigid)/D412(elastomer)	23
Flex Strength (MPa)	ASTM D790	52
Flex Modulus (MPa)	ASTM D790	1500
Izod Notched Impact (J/m)	ASTM D256	34
Izod unnotched impact (J/m)	ASTM D4812	90
Tg (DMA, E")	ASTM E1640 (E"at 1°C/min)	50
HDT @ 66PSI (C)	ASTM D648	65
HDT @ 264 PSI (C)	ASTM D648	48
CTE above Tg ((µm/m)/°C)	ASTM E831	171
CTE below Tg ((µm/m)/°C)	ASTM E831	95
Shore D Hardness	ASTM D2240	79
Shore A Hardness	ASTM D2240	n/a
24 Hour water absorption (%)	ASTM D570	0.61
Tear Strength (kN/m)	ASTM D624	n/a

4.1.22 Properties Figure 4 Tough 65C Black

METRIC	METHOD	VALUE
Color	N/A	Black
Description	N/A	Versatile utilities with a good combination of impact strength, elongation, and tensile strength. Long-term Indoor and Outdoor environmental stability.
Speed (mm/hr) - 50 µm Print Mode/ Standard Build Style	Internal Method	Up to 30
Viscosity (cps @ 25C)	Brookfield viscometer	1900
Liquid Density (g/cm3)	Kruss K11 Force Tensiometer	1.13
Solid Density (g/cm3)	ASTM D792	1.22
Tensile Strength Ultimate (MPa)	ASTM D638 (rigid)/D412(elastomer/ rubber)	41
Tensile Strength @ Yield (MPa)	ASTM D638	40
Tensile Modulus (MPa)	ASTM D638 (rigid)/D412 (elastomer)	1700
Elongation at Yield (%)	ASTM D638	6.6
Elongation at Break (%)	ASTM D638 (rigid)/D412(elastomer)	35
Flex Strength (MPa)	ASTM D790	55
Flex Modulus (MPa)	ASTM D790	1600
Izod Notched Impact (J/m)	ASTM D256	31
Izod unnotched impact (J/m)	ASTM D4812	100
Tg (DMA, E")	ASTM E1640 (E"at 1°C/min)	50
HDT @ 66PSI (C)	ASTM D648	70
HDT @ 264 PSI (C)	ASTM D648	51
CTE above Tg ((µm/m)/°C)	ASTM E831	163
CTE below Tg ((µm/m)/°C)	ASTM E831	92
Shore D Hardness	ASTM D2240	81
Shore A Hardness	ASTM D2240	n/a
24 Hour water absorption (%)	ASTM D570	0.62
Tear Strength (kN/m)	ASTM D624	n/a

4.1.23 Properties Figure 4 TOUGH-BLK 20

Figure 4 TOUGH-BLK 20

METRIC	METHOD	VALUE
Color	N/A	Black
Description	N/A	Rigid, black plastic with industry-leading UV stability. It is ideal for high-performance, functional prototyping applications.

METRIC	METHOD	VALUE
Speed (mm/hr) - 50 µm Print Mode/ Standard Build Style	Internal Method	Up to 45
Viscosity (cps @ 25C)	Brookfield viscometer	2623
Liquid Density (g/cm ³)	Kruss K11 Force Tensiometer	1.04
Solid Density (g/cm ³)	ASTM D792	1.11
Tensile Strength Ultimate (MPa)	ASTM D638 (rigid)/D412(elastomer/ rubber)	40.4
Tensile Strength @ Yield (MPa)	ASTM D638	40.4
Tensile Modulus (MPa)	ASTM D638 (rigid)/D412 (elastomer)	1775
Elongation at Yield (%)	ASTM D638	4.6
Elongation at Break (%)	ASTM D638 (rigid)/D412(elastomer)	36
Flex Strength (MPa)	ASTM D790	60.5
Flex Modulus (MPa)	ASTM D790	1646
Izod Notched Impact (J/m)	ASTM D256	27
Izod unnotched impact (J/m)	ASTM D4812	1008
Tg (DMA, E")	ASTM E1640 (E"at 1°C/min)	46
HDT @ 66PSI (C)	ASTM D648	55
HDT @ 264 PSI (C)	ASTM D648	45
CTE above Tg ((µm/m)/°C)	ASTM E831	173
CTE below Tg ((µm/m)/°C)	ASTM E831	83
Shore D Hardness	ASTM D2240	78.6
Shore A Hardness	ASTM D2240	n/a
24 Hour water absorption (%)	ASTM D570	0.31
Tear Strength (kN/m)	ASTM D624	n/a

4.2 Figure 4 Standalone Material Expiration Date

The printer screen will notify you if your resin is expired upon scanning. The expiration date can also be found on your material bottle.

5 FIGURE 4 STANDALONE FACILITY REQUIREMENTS

This guide provides you with information on how to properly prepare your facility for the Figure 4 Standalone Printer. This chapter introduces you to the Figure 4 Standalone Printer machine and other system components - including lists of other support equipment and supplies that you will find helpful in setting up your facility.

Additional chapters include guidelines for the following:

- [Site Selection](#) - gives information on how much space the Figure 4 Standalone Printer requires and the necessary services and equipment needed for a highly efficient, ideal location for your Figure 4 Standalone Printer and its components.
- [System Delivery](#) - provides information about preparing for the delivery of your Figure 4 Standalone Printer.
- [System Installation](#) - explains the process of, and requirements for, installing the Figure 4 Standalone Printer in your facility.
- [Considerations for Material](#) - gives you guidelines for proper storage, handling, and safety for Figure 4 materials.
- [Third-Party Equipment and Supplies](#) - provides a summary of the optional equipment and supplies that 3D Systems recommends for efficient and complete part building, post processing, and finishing.

5.1 Figure 4 Standalone 3D Sprint Software

System Requirements

Included with the system is the part-preparation (3DSprint™) software. This application provides part preparation and part building functionality. The 3DSprint software is installed on a separate, customer-supplied computer. The following page contains the minimum computer configuration requirements for the 3D Sprint computer: https://support.3dsystems.com/s/article/3D-Sprint?language=en_US. Scroll down and click the 3D Sprint System Requirements link.

5.2 Site Selection - Figure 4 Standalone Printer

This section provides the requirements and recommendations to determine the most appropriate location for a highly functional, efficient Figure 4 Standalone Printer workspace, with room for other equipment and supplies. To help you choose a location, the [Initial Site Survey Checklist](#) provides the attributes that you need to select the best location for your installation. After narrowing the list of possible locations, consider each requirement carefully before making a decision about your final placement site.

5.2.1 Figure 4 Standalone Part 1

Space Requirements

User preferences, building codes, and equipment configuration help you to define the total floor area that your Figure 4 Standalone Printer will need. The Figure 4 system should be located in an environmentally controlled room. Locate the secondary post processing equipment and supplies in the same room or adjoining room, if possible. The figure below shows an ideal site configuration that minimizes the required movement of parts after part building. The [Figure 4 Standalone Printer Measurements Diagram](#) shows the minimum dimensions of the Figure 4 Standalone Printer. Your site layout will vary.



Note: Due to UV safety requirements, the system should be located where access to the room can be avoided during an emergency.



Note: The Figure 4 Standalone Printer should be placed such that the front of the unit is easily accessible for opening the door and loading/unloading print platforms. There should also be at least six inches of clearance on the sides and back of the printer for proper air flow. If you use the pedestal, the outriggers hitting the wall will add the required clearance. You may wish to use an Uninterruptible Power Supply (UPS) to keep your devices running in the event of a power surge/outage.

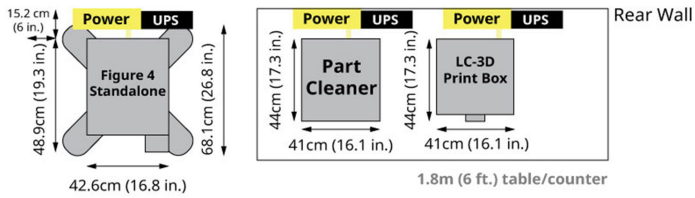

Optimal Site Layout (top view) - dimensions for part cleaner are based on a popular consumer ultrasonic cleaner

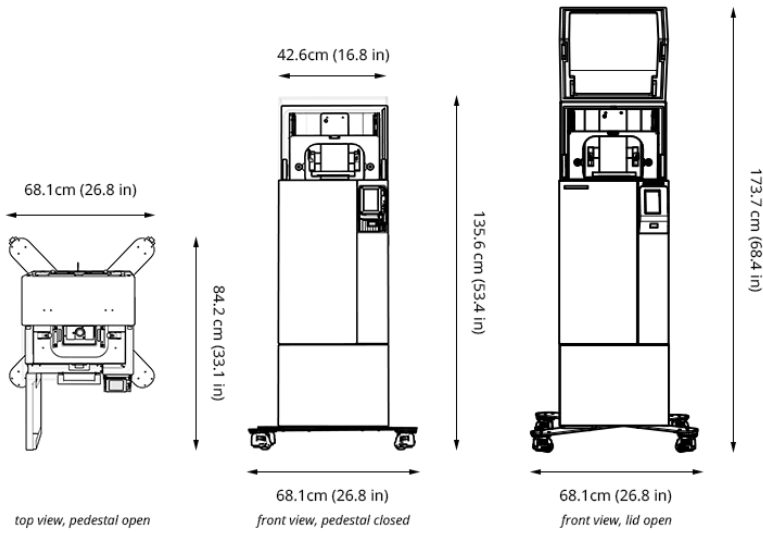

Printer dimensions with pedestal

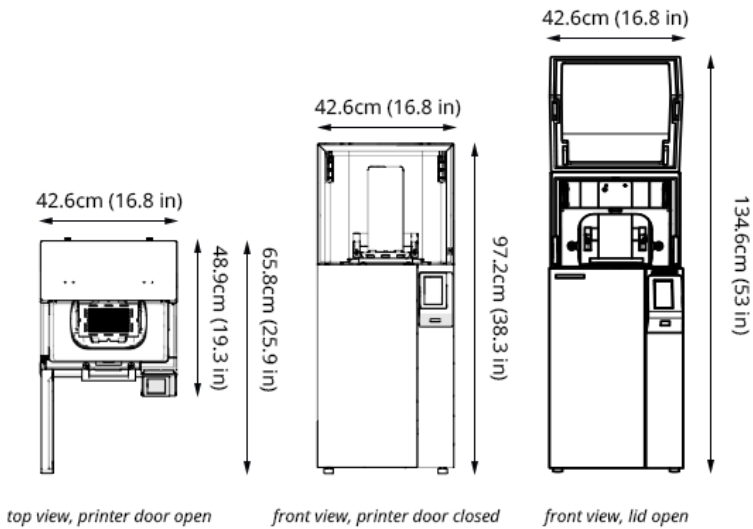

Printer dimensions without pedestal

Internet Connection

There must be a wired internet connection for the printer to connect to. The Figure 4 Standalone Printer communicates with a 3D Systems server and will not operate on a closed network. There is also no WiFi support. Once connected, the printer will use the internet as illustrated below.

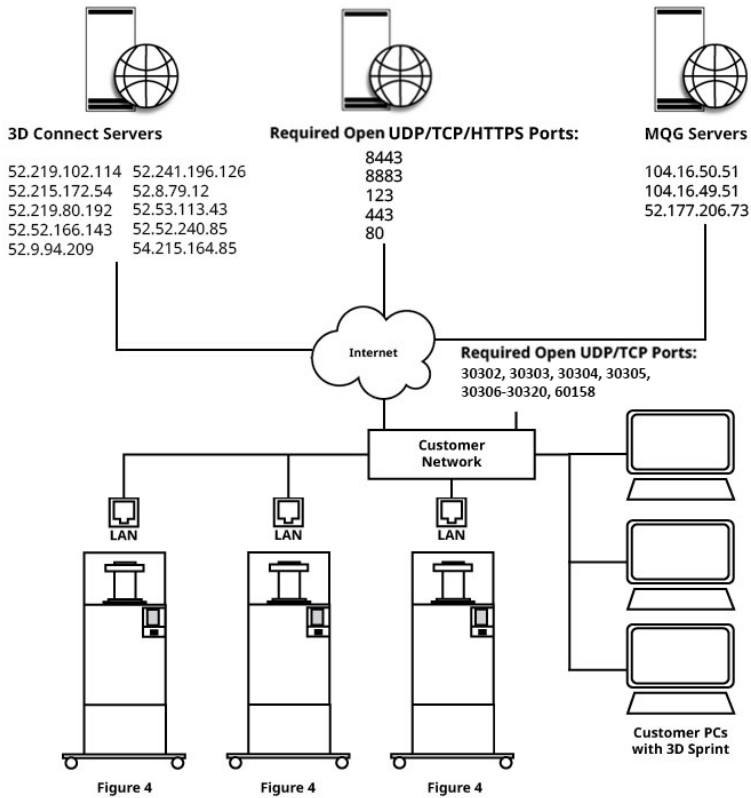

In addition to these requirements, ensure that your network meets the following criteria:

MQG network requirements:

- The following IP addresses are made as an exception on your firewall:
 - 104.16.50.51 - <http://www.3dsystems.com>
 - 104.16.49.51 - <http://www.3dsystems.com>
 - 52.177.206.73 - MQG server mqg.3dsystems.com
- Your printer is on the internet via at gateway/NAT.
- NTP UDP 123 port is open
- Port 80 is open

3D Sprint network requirements:

- Ensure UDP/TCP ports 30302 through 30320 and 60518 are open on the LAN.

3D Connect service IP addresses

The following IP addresses are made as an exception on your firewall:

52.219.102.114 52.215.172.54 52.219.80.192 52.52.166.143 52.9.94.209 52.241.196.126 52.8.79.12 52.53.113.43 52.52.240.85
 54.215.164.85 Ports 443, 8443, and 8883 are open with encrypted connections.

If any 3D Connect IP address is not white-listed, a 3D Connect error may appear on the printer (either code 3490120 or 3490121). This error will not affect printer operation and can be disregarded.

3D Connect sends the following data to 3D Systems servers from your printer:

Device	build.job_data* chamber_door.state lifetime_build_hours lifetime_on_hours printer_name printer_state serial_number
Conditions	fault.controller.internal_temperature fault.controller.internal_temperature_override fault.sata.drive.failure
Build	build.abort_code build.current_layer build.progress build.time_remaining

Controller	controller.internal_temperature controller.ip_address controller.mac_address controller.secure_device_read_failure_count controller.serial_number controller.version controller.version_date
Exhaust Filter	exhaust_filter.carbon_filter_element_hours
Projector	projector.led_power_commanded projector.led_pwm_value projector.led_total_hours projector.manual.compensation projector.power_cal_table projector.serial_number projector.total_hours
Stock	stock.barcode stock.batch_expiration_date stock.batch_number stock.bottle_size stock.bottle_sku stock.bottle_udi stock.label_current_used_amount stock.label_last_used_date stock.label_uuid stock.material_code stock.material_density stock.material_exposure stock.material_name stock.material_shade
Z Motor	z_motor.position
Build Job Data	job_id total_layers extent_units x_extent y_extent z_extent material material_estimated_total material_estimated_total_volume build_time_estimate submit_time start_time completion_time build_mode status status_change_time

Other Requirements

The printer runs local DHCP servers for two static local/hardware connections:

- 192.254.1.100
- 192.168.7.2

Your network cannot use these IP addresses for one of your printers.

Floor/Area Surface

Floors and counter spaces in the Figure 4 work area should be non-porous and suitable for cleaning with solvents. The feet of the printer must be on a sturdy, level surface; be sure to make any leveling adjustments needed to the desk/counter your printer will be on. Carpeted floors must not be used. Remove any carpeting or other non-porous flooring where the feet of the Figure 4 system will be placed. The system should not straddle any floor/desk/counter seams. The maximum permissible platform incline is 2.5 cm/12 m (1 in/40 ft).

Floor Vibration and Shock

The system is a precision mechanical and optical machine that is sensitive to vibration. In order to ensure part quality and accuracy, a ground floor location with a concrete floor, (miminum of 4 inches thick) is recommended.

The Figure 4 Standalone is slightly self-damping, and should not be affected by normal or incidental environmental vibration; however the area should be isolated, either via location or some other physical or mechanical means, from any significant internal or external vibration sources such as heavy machinery, HVAC and fans. Locations near airports or train tracks which could cause unacceptable shock or vibration levels are not recommended.

Load-Bearing Capacity

The Figure 4 Standalone Printer is 34.5 kg (76 lbs) and does not require a table rated for a heavy load. Additional equipment, such as a UV oven or ultra-sonic cleaner, will each have their own loads for your setup to bear. Refer to the [Weights and Measures Charts](#) to determine the total weight of the equipment to be housed in your room to ensure that you do not exceed the maximum load-bearing capacity that your printer-staging area can support.

Electrical Requirements

Electrical voltage requirements for the Figure 4 Standalone Printer:

- 120V-240V, 50/60 Hz, 4A (2A Europe), 1 phase

Power for the Figure 4 Standalone Printer should be on a surge-protected circuit. 3D Systems does not require the use of a UPS (Uninterruptible Power Supply) for the Figure 4 Standalone Printer. However, if you live in an area with frequent power surges/outages, a UPS would be useful. A UPS would prevent a build from crashing in the event of a brief power outage/surge, as it would give you time to properly pause the print job.

Ensure that the space you select for the printer has a power outlet reachable by that length of cord. Use of an extension cord or power strip is not recommended.

If your power cord becomes damaged or lost, please ensure you order a replacement from 3D Systems for a power cord that is adequately rated for the machine. Do not replace the power cord with a cord that is not rated for the printer. 3D Systems will identify any parts that are required to be examined or supplied only by 3D Systems or its partners.

5.2.2 Figure 4 Standalone Part 2

Heat Dissipation

The Figure 4 Standalone Printer is not expected give off significant heat under normal operating conditions.

Connection to AC Power

- In the United States, connection to a standard 10-amp wall outlet is required. The system connects to a 120VAC power outlet through a standard 120VAC power cord.
- In Europe, a standard 10-amp wall outlet is also required. The system connects to a 230VAC power outlet through a standard 230VAC power cord. Country destination kits are available with the proper wall-power connections.

Temperature

The temperature in the room or location where the Figure 4 system resides should remain stable to allow optimal system operation and optimal part quality.

Figure 4 resins should be stored between 5°C-30°C (41°F-86°F). However, successful printing has only been tested at a minimum of 18°C (64.4°F) and a maximum of 28°C (82.4°F)*. If your room is kept beyond either extreme, you may see a degradation in print quality.

*For Figure 4 FLEX BLK 10 print material, printing temperatures outside the range of 10-30°C (50-86°F) can cause printed-part properties to change.

Humidity

The optimal humidity in the Figure 4 Standalone Printer build chamber and lab will depend to a certain degree on the Figure 4 material selection. Regardless, the humidity should always be non-condensing and should not vary outside the range of 30 to 70% RH*. Review your Figure 4 material information (SDS, User Guide, and product labeling) for specific information on recommended humidity levels.

*For Figure 4 FLEX BLK 10 print material, humidity outside the range of 10-65% RH can cause printed-part properties to change.

Altitude

The Figure 4 system is capable of operating correctly up to an altitude of 2,400 m above mean sea level.

Ventilation

While outside venting is not always required, there are some materials for which outside venting is necessary. Your HVAC system should perform at least six air exchanges per hour in the room where the printer is located. You may wish to have a fume hood installed for your part-cleaning area. Ensure that your facility complies with all local and regional regulations regarding ventilation of vapors, dust, and other by-products of printing, cleaning and secondary processing. Always refer to and follow the information on the SDS for your specific material.

5.2.3 Figure 4 Standalone Part 3

Overall Sound Pressure Level (OASPL)

The sound of the Figure 4 system will not exceed 80 db.

Air Cleanness

The room housing the Figure 4 system should be prepared for odors related to a small material spill. The means that windows should be able to be opened and/or other measures can be put in place to vent the room in the case of a spill. Reasonable care should be taken to minimize dust and smoke which could contaminate the Figure 4 material and cause deterioration of

optical surfaces. Avoid temperature fluctuation. Since dust, smoke and temperature fluctuations can affect the performance of the machine and the quality of the parts, an area with filtered air flow is recommended. Avoid proximity to machine shop areas, or where milling, grinding, or sanding is performed.

Lighting

Standard fluorescent lamps with clear plastic diffusers are recommended to minimize ultraviolet exposure, which could negatively affect the Figure 4 material. Sunlight, quartz-halogen lamps, and high-intensity incandescent lamps are not suitable; and UV-intensive lighting or ultraviolet exposure through windows should be avoided. UV filters are available for windows and exposed fluorescent lamps. Any exposure of the resin to any of the light sources described in this section is likely to cure the resin, thereby wasting it and forcing a difficult cleanup.

Door or Other Method of Preventing Access to Room

The site should be able to be isolated from other employees or personnel in the event of a material spill or major machine malfunction. A separate room or area that can be closed to others is necessary. The system is safe and does not present hazards to properly trained personnel operating the system in accordance with our specifications. However, the system should be installed in an area that can be cleared of untrained personnel during emergency situations.

Network Access

The Figure 4 system controller computer includes a Class A Ethernet interface, which can be connected to a 10/100/1000 MBit/s Ethernet network to offer network access to the Figure 4 system. To remotely operate the Figure 4 Standalone Printer or to remotely run service engineer diagnostics, a VPN network access is required.

Telephone Service

Dedicated telephone lines are not required for normal operation of a Figure 4 system. You may wish to install a dedicated telephone line in the Figure 4 system installation area to facilitate discussions with 3D Systems Customer Service personnel while the machine is in operation, should the need arise.

5.3 Figure 4 Standalone Site Selection - Post Processing Equipment

Locating the post-processing equipment is similar in many respects to locating the Figure 4 Standalone Printer. The following abbreviated site specifications are for recommended post-processing equipment.

Space and Location Selection

You may choose to locate the part-washing, drying, and curing stations in the same room as the Figure 4 Standalone Printer or in a room adjoining the printer

With either option, please consider the following:

1. The further the distance the build part is being moved from the printer to the post-processing area, the longer the opportunity for the build part to get damaged by dropping, bumping into objects, and other environmental factors.
2. The further the distance the build part is being moved, also longer is the opportunity for uncured resin to drip onto the floor. If floors are porous, such as carpeting or some tiles, they can absorb the spilled resin and would need to be professionally cleaned or replaced.

Refer to [Optimal Site Layout](#) for a suggestion for overall layout. Refer to the [Weights and Measures Charts](#) for weights and measurements of the LC-3DPrint Box. Consider the following additional specifications when selecting the location for your post-processing equipment.

NextDent LC-3DPrint Box Measurements

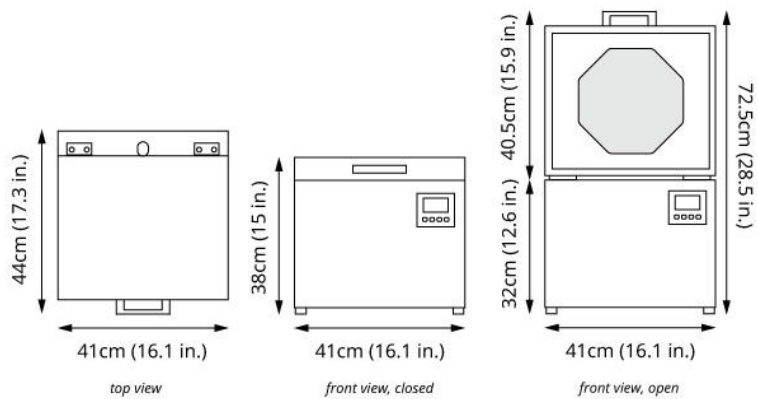

Floor Surfaces

Flooring/table/countertop under the post-processing equipment should be non-porous and suitable for cleaning with solvents. Carpeted floors are not recommended.

Electrical Requirements

NextDent LC-3DPrint Box

Power configuration: 110V/240V - 50/60Hz - 2.6A/1.3A

Electrical power for the LC-3DPrint Box must be on a surge-protected circuit. A UPS, while not required, is recommended in areas with frequent power fluctuations, as surges and spikes can damage electronic components and power loss can damage the unit.

Ultrasonic Cleaner

Power configuration: An example of the power configuration for a consumer-grade ultrasonic cleaner is 120W at 40,000Hz. There are ultrasonic cleaners of many sizes, from around 2.5L (0.66 gal.) to upwards of 757L (200 gal.) Determine which size ultrasonic cleaner is best for your needs.

You must also get an ultrasonic cleaner that is rated to use flammable solvents like IPA. Failure to do so could present a fire hazard.

Electrical power for an ultrasonic cleaner must be on a surge-protected circuit, particularly for a bigger (not desktop) cleaner. A UPS, while not required, is recommended in areas with frequent power fluctuations, as surges and spikes can damage electronic components and power loss can damage the unit.

Connection to AC Power

The LC-3DPrint Box is designed to plug into a standard power outlet in different countries. Smaller ultrasonic cleaners will also plug into standard wall outlets; bigger ones, however, may require a custom power outlet.

Ventilation (Ductwork)

The post-processing equipment may be vented outside if required by your facility; however, ventilation is not required by 3D Systems. Contact your Facilities Manager for your requirements.



CAUTION: Never disconnect a ducting system that is connected to an external extraction system.

5.3.1 Figure 4 Standalone Third Party Supplies and Equipment

3D Systems™ provides this partial list of equipment and supplies/accessories that are useful for handling, processing or finishing Figure 4 parts. You should keep a list of preferred vendors for any 3D-print-related products you may order. Equipment and supplies are not limited to this list, as you may find other products and methods that more suit your needs.



Note: Customers are responsible for consulting local health, safety, and environmental regulations to determine additional site requirements. No information that is contained in this document constitutes legal advice regarding such requirements. 3D Systems™ has no responsibility to determine whether or not the

customer is in compliance with applicable laws, nor do we guarantee the accuracy or quality of the supplier product.

Uninterruptible Power Supply (UPS) - While a UPS is not required for use with the Figure 4 Standalone Printer, you may wish to use one for battery backup of your printer in the case of a power surge or outage.

UV Filter Screens - While these are not required, you may need to install filters over windows and lights so as not to cure any exposed print material before printing.

Disposable Lint-Free Paper Towels - You will use lint-free paper towels for assisting in cleaning printed parts, printer components, and resin spills.



CAUTION: It is necessary to use lint-free paper towels, as lint from other types of paper towels can stick on the printed part or printer component. Lint on the printed part can cause improper final part curing in the UV oven. Lint on printer components can contaminate the resin on the print platform and in the resin tray, causing the printed part to lose accuracy or causing a build to crash.

Clean-Room Swabs - You will need clean-room swabs to clean the projector lens.

Cellulose Wadding - This absorbent material is useful for covering your Figure 4 workbench, as well as for absorbing solvents during air drying of printed parts.

Chemically Resistant Gloves - 3D Systems recommends the use of 100% nitrile gloves whenever handling uncured resin, partially cured printed parts, and solvents.

Eye-Wash Station - This may be designed specifically for eye-washing or may be an adapter that fits onto an existing faucet.

Fire Extinguisher - NFPA Class B such as CO₂, dry-chemical, or foam

Hazardous-Materials Waste Can - While it is optional to get a fire-proof waste can, you must have a waste can approved to contain Figure 4 resins, according to all local, state, and federal regulations.

Storage Cabinet - This is for storing resin bottles and other Figure 4-related equipment. You may choose to get a fire-proof cabinet; but it is not required to be fire-proof.

Lab Coats - Optional measure to protect your clothes/skin from uncured print material and solvents.

IPA, EZ Rinse C, Propylene Carbonate, and/or 5 wt% Elma Tec A4 Solution - These solvents are used in cleaning printed parts, printer components, and areas where resin has spilled.

Safety Glasses (405 nm radiation blocking) with side shielding - The printer operator should not be exposed to hazardous radiation from the printer or curing oven. However, in the case of an emergency where radiation emits from these devices, it is recommended to wear eye protection.

NextDent LC-3DPrint Box - Please see the section [LC-3DPrint Box](#) for more information.

NextDent LC-3DMixer - Please see the section [LC-3DMixer](#) for more information.

5.4 Figure 4 Standalone System Delivery

After placing your order, a 3D Systems™ representative will contact you to confirm your shipment delivery date. Ensure that the area where you intend to place your Figure 4 Standalone Printer is ready to move the system into, and that you have the assistance of another person or lifting device, such as a hand truck, before scheduling the shipment of your printer. The following information will guide you through this preparation phase.

Preparation for Receiving

Inform your receiving personnel that the items you ordered will be arriving and arrange for a location to store them until you are ready to install the printer and any accessories.

Transporting the Figure 4 Standalone Printer

When you open the printer crate, use the help of another person or a hand truck to help move the system. If you do not have a hand truck or another person on-site to help you, arrange to have one or both of these aids beforehand.

Shipment Arrival

The Figure 4 Standalone Printer will arrive in a variety of crates and/or pallets - the largest crate being for the Figure 4 Standalone Printer. Your shipment will consist of the following items:

- Figure 4 Standalone Printer
- Pedestal
- Start-up Kit

- Resin Tray
- Print Platform (x2)
- Power Cord/Power Brick
- LC-3DPrint Box - the recommended post-curing oven for the printer's resins

Optional items you could have in your shipment:

- LC-3DMixer - to agitate bottles of resin to keep their contents mixed properly. Please see the SDS/Instructions for Use of a specific resin for mixing instructions.
- Ultrasonic Part Cleaner (ordered separately from third party)

Once your shipment arrives, first inspect the crates for any physical damage. Then, after inspection, receive the crates.

The following charts list both crated and uncrated dimensions and weights for different products that you may have ordered. Verify your order and compare to the listed items below. Crate or pallet dimensions and weights may vary.

BOXED SPECIFICATIONS				
Product	Width	Depth	Height	Weight
Figure 4 Standalone Printer	73.7 cm (29 in)	68.6 cm (27 in)	129.5 cm (51 in)	59 kg (130 lbs)
Figure 4 Standalone Pedestal	82.6 cm (32.5 in)	79.4 cm (31.3 in)	55.2 cm (21.8 in)	26.3 kg (58 lbs)
LC-3DPrint Box	54.5 cm (21.5 in)	57.5 cm (22.6 in)	59.5 cm (23.4 in)	28.9 kg (63.8 lbs)
UNBOXED SPECIFICATIONS				
Product	Width	Depth	Height	Weight
Figure 4 Standalone Printer	42.6 cm (16.8 in)	48.9 cm (19.3 in)	97.2 cm (38.3 in)	34.5 kg (76 lbs)
Figure 4 Standalone, with pedestal	64.4 cm (25.4 in)	66.8 cm (26.3 in)	136.3 cm (53.6 in)	56.3 kg (124.1 lbs)
LC-3DPrint Box	41 cm (16.1 in)	44 cm (17.3 in)	38 cm (15 in)	22 kg (48.5 lbs)

Inspect Exterior of Printer

Visually inspect the exterior of the printer for any damage incurred during shipping. Notify your reseller immediately if any damage is evident at this point. DO NOT proceed with the installation until you have discussed the damage with your reseller.

5.5 Figure 4 Standalone System Installation

Installation of your system encompasses four separate steps:

1. Purchase and arrival of third-party equipment or supplies you may have ordered.
2. Delivery of your Figure 4 system shipment.
3. Uncrating and installation of your Figure 4 system components.

System Uncrating

The uncrating and installation of the Figure 4 Standalone will be performed by the printer operator. The weight of the printer requires a minimum of two people to lift it safely.

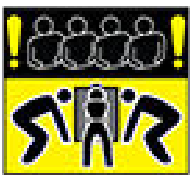

Scheduling Time for Your Installation

The installation of the system should only take an hour or less.

Preparing for System Installation

In preparing your facility for Figure 4 system placement, you must consider four main factors:

- Make sure that you have the necessary doorway and passageway clearance to move either the crated or uncrated components to their final destinations, including space for the people who are carrying the unit.
- Make sure that you have an adequate pallet jack, hand truck, or another person to help move the system and its accessories.
- If you use equipment to lift the printer, verify that it is rated for the load of the system components.
- Do not prepare a desk/table/countertop for the printer unless it is rated to hold a load of at least 34.5 kg (76 lbs).

Minimum Passageway and Door Openings

Most standard doorways and halls provide adequate access for moving the system. If the Figure 4 Standalone Printer is lifted on its narrow side, each passageway and doorway must be wide enough to move and turn a printer measuring 42.6 x 48.9 x 97.2 cm (16.8 x 19.3 x 38.3 in), in addition to accommodating the people or equipment used to move the printer.

Determine the pathway from where the crated components are stored to where your Figure 4 system will be installed. Walk the path from the storage location to the final destination of the system, and measure any critical doorways or passageways to ensure that the equipment can be moved through the area.

If a passageway or doorway is too small for the crated Figure 4 system, it may be necessary to remove the Figure 4 system from its crate before moving the unit. A standard door that is 2-2.4m (6.5-8 ft) tall and 0.61-1.1m (2-3.5 ft) wide should accommodate the system and its accessories.

5.6 Figure 4 Standalone Considerations for Material

You are responsible for ensuring that the facility where your Figure 4 system and Figure 4 materials are housed is properly configured for safe operation of the Figure 4 system and of the materials used in that system. Personnel who operate the equipment or use the materials must comply with all relevant safety codes and applicable regulatory requirements and laws, particularly those that relate to usage of hazardous chemicals, radiation, and disposal of regulated material. The Figure 4 Standalone Printer complies with CE requirements.



Note: You are responsible for determining whether additional supplies and equipment are necessary according to local, state, federal or other regulatory laws that govern your location.

Figure 4 Material Usage

Figure 4 materials in the liquid state require use of approved surgical-type 100% nitrile gloves and other equipment to protect the user from direct contact with uncured print material. Material is fully cured only after adequate exposure in the LC-3DPrint Box or similar UV oven. Only after being fully cured do the parts no longer require protective gloves to handle.

Material Disposal

Because Figure 4 materials are regulated, they are subject to special disposal requirements by your local, federal, or other regulatory agencies. Follow applicable disposal guidelines. Contact a local waste management company for recommendations on disposal requirements that affect your facility.

If your area requires regulated waste disposal, consult with and retain a waste-management company to periodically pick up regulated waste. Your local waste management company may recommend that you set up a drum, or other approved container, to dispose of liquid material, partially cured printed parts (also called "green" parts), and of any materials (such as paper towels or gloves) that may have come into contact with the uncured liquid material.

After final part curing in the LC-3DPrint Box, fully cured Figure 4 parts may be disposed of in regular trash receptacles.



Note: Inspect printed parts after curing in the LC-3DPrint Box to ensure they are fully solidified. Part-surface tackiness and visible or discernible areas of liquid material indicate the part is not fully cured.

Storage and Usage Guidelines

Please see the section [Material Handling and Safety](#) for more information. Always read the Safety Data Sheet (SDS) prior to use of any Figure 4 material.

5.7 Figure 4 Standalone Advance Preparation Checklist



Note: Unless governed by prior arrangement, 3D Systems is not responsible for loading 3D Sprint software on the user's workstation(s). Thus, BEFORE THE 3D PRINTER SYSTEM ARRIVES, ensure that your workstation is capable of supporting the requirements of both 3D Sprint software and communication with the printer via your network.

If you wish to fill out this form by hand:

Press ctrl+P (cmd+P on Mac) to print this page. Fill out the form, make a copy for yourself, and fax/email it to your reseller.

If you wish to fill out this form on your computer:

Fill out the information in ALL the fields, and then press ctrl+P (cmd+P on Mac) to print the document. Then sign and date the document by hand, make a copy for yourself, and fax/email it to your reseller.

Checklist

Review this list with a network administrator, IT department, facilities manager, and/or other responsible person within your organization. Please complete the following information:

This is NOT an online form and CANNOT be submitted on this webpage. The form must be printed out and faxed/emailed.

Company Name:

Telephone (with area code):

Contact (print full name):

Date faxed:

Email:

Please place a check in each box once that item is complete.

- Operating system and workstation configurations are compatible and meet the minimum requirements as stated in the [3D Sprint Software section](#) .
- Final installation site is selected. The intended physical location for the printer should be selected in advance, and checked for adherence to the [guidelines set out in this guide](#) .
- Flooring where printer will be located is [non-porous](#) , has an incline of less than/equal to 2.5 cm/12 m (1 in/40 ft), and is isolated from significant sources of vibration.
- Flooring can take the [total weight](#) of all system components combined in the room(s) they are in.
- [Enough surge-protected circuits](#) have been installed to accommodate the number of printers, and other products, ordered. Enough power outlets have been installed on these circuits.
- If desired/required, you have purchased enough uninterruptible power supplies (UPS) for the number of printers, and other products, ordered.
- You have a print-material-storage area set up that can be kept at [5°C-30°C \(41°F-86°F\)](#) . Temperature of 3D-printing room can be kept at 18-28°C (64.4-82.4°F).
- 3D-Printing room can be kept between [30-70% relative humidity](#) (RH).
- 3D-Printing room is less than 2,400 m (1.5 mi) above mean sea level.
- HVAC can perform at least six air changes per hour and 3D-Printing room is [well-ventilated](#) and has clean air.

- 3D-printing room lighting is either fluorescent lamps with clear-plastic diffusers, or has sufficient UV filters covering its lights.
- Both the 3D-printing room and material-storage area can be isolated in the event of a resin spill or open-radiation Service call.
- A method of removing the crate from the shipper's truck [has been arranged](#) , such as a pallet jack or forklift, and is available to transfer the crate(s) to the uncrating location.
- For removing the printer from its crate, you have another person available to help [team lift it](#) . For transporting the uncrated printer within your facility, you have the help of another person or hand truck.
- Your receiving area, hallways, and 3D-printing room have the [necessary doorway/passageway clearance](#) to move either crated or uncrated components of the Figure 4 Jewelry system.
- You have set up [hazardous waste containers](#) , as well as arranged for a company to dispose of your hazardous waste according to all government regulations.
- You have purchased any desired [third-party supplies and equipment](#) .

Network Information

- Enough Cat-5e/Cat-6 Ethernet outlets have been installed to accommodate the number of printers you have ordered.
- Network conforms to the specifications [listed in this guide](#) .

Post-Processing Equipment

- Final installation site is selected. The intended physical location of your post-processing equipment should be selected in advance, and checked for adherence to the [guidelines set out in this guide](#) .
- For the LC-3DPrint Box: A surge-protected circuit with space for a 1.3A (2.6A USA) machine is available.
- If purchasing an ultrasonic cleaner, it is rated for use with flammable solvents like IPA (isopropyl alcohol). Larger ultrasonic cleaners may require a dedicated circuit and/or power outlet. Check with your ultrasonic cleaner supplier.
- If desired/required, you have purchased enough uninterruptible power supplies (UPS) for your post-curing units and ultrasonic cleaners.
- If desired/required, fume hoods have been installed in your part-cleaning/curing areas.

Before the printer is installed into this facility, we acknowledge that the installation site complies with the specifications stated in the NextDent 5100 Facility Requirements Guide. Once the printer is installed, we agree not to alter any of the required specifications listed in this manual without consulting with a 3D Systems' Customer Service Representative or certified partner. If alterations are made without consulting 3D Systems, it may void the system's warranty.

Customer Signature:	Date:
 <hr/>	 <hr/>

6 FIGURE 4 STANDALONE SETTING UP YOUR PRINTER

The following items and accessories are contained in the printer package.

Figure 4 Standalone Printer



Resin Tray - Contains the print material during part building.



Print Platform (x2) - The 3D-printed part adheres to the print platform during part building.

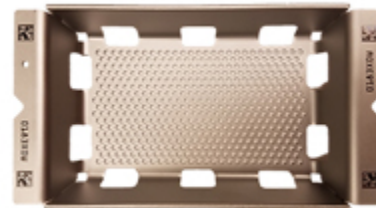

Catch Tray - Prevents resin spills from entering the lower build chamber, should the resin-tray membrane be punctured. This comes installed in the printer.



Power Cord (country specific) - To connect printer to power source. The power cord has been packaged with your printer by your reseller to ensure you receive the correct power cord for your region.



Resin Mixer - Used to mix the liquid Figure 4 resin while in the resin tray



Punch Tool - Used to remove the printed part from the print platform from underneath, and to clear the print-platform holes of partially cured resin.



Carbon Filter - Prevents print-material fumes from exiting the process chamber. You will install this in the Carbon-Filter Bracket, as seen below.



Resin Tray Garage - Used to cover a resin-filled resin tray inside or outside the printer, so as to protect it from UV-light exposure and external contaminants



Platform Scraper - Used to scrape any residual partially cured material off the print platform



Intake Filter - Keeps dust out of the printer while feeding air to the cooling fan



Bubble Level - Used to level the printer before its first use



Part-Cleaning Brush - Used to aid in cleaning partially cured resin off the print platform and printed part



Platform-Cleaning Fixture - Used to hold the print platform in a tub of solvent during platform cleaning

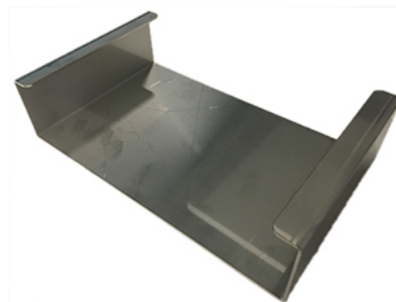

Ethernet Cable



Wire Brush - Used to help clean print platforms that have run ELAST-BLK 10 resin



6.1 Figure 4 Standalone Necessary Accessories

LC-3DPrint Box or other UV-curing oven



Material Bottles - The Figure 4 Standalone Printer uses various Figure 4 print materials, which come in 1kg bottles. Please see the section [Material Bottles](#) for a complete list of currently supported print materials.



6.2 Figure 4 Standalone Optional Accessories

LC-3DMixer - This is the recommended solution for mixing Figure 4 resins. Please see the section [Mixing, Stirring, and Curing Chart](#) for more information.



Pedestal - to sit your Figure 4 Standalone Printer on top of and store frequently used tools. It also allows for easy movement of the printer on its wheels. The pedestal is included with your shipment, but is not required for the printer to function properly.



Ultrasonic Cleaner - Along with this, you should have stainless-steel and/or glass containers in which to place printed parts during cleaning.



Note: 3D Systems does not supply an ultrasonic cleaner. Please purchase the cleaner that is best for you from your local supplier.



This image is for example purposes only and is not a recommendation or endorsement of any brand of ultrasonic cleaner.

6.3 Figure 4 Standalone Unpacking the Printer

Please see Printer unpacking instructions in the Quick-Start Guide on the page [Guides Inside the Box](#) .

6.4 Figure 4 Standalone Unpacking the Pedestal

Please see Pedestal unpacking instructions in the Quick-Start Guide on the page [Guides Inside the Box](#) .

6.5 Figure 4 Standalone Place Printer on Pedestal

Please see instructions for placing the Printer on the Pedestal in the Quick-Start Guide on the page [Guides Inside the Box](#) .

6.6 Figure 4 Standalone Level the Printer on Pedestal

Please see instructions for leveling the Printer on the Pedestal in the Quick-Start Guide on the page [Guides Inside the Box](#) .

6.7 Figure 4 Standalone Nesting Printers

If you have multiple Figure 4 Standalone printers on pedestals, you may use a technique called, "nesting," to set up the printers as closely as possible while still enabling access to all printer doors. This section describes how to nest three printers together. However, you could nest as little as two, and as many as your facility allows.

1. The printer that will be in the center of your "nest" should have all its leveling feet locked down so that the printer does not move. This is important for future steps so that only the printer you intend to adjust moves.
2. Ensure that the leveling feet on all the other pedestals are raised up to allow the printers to roll.

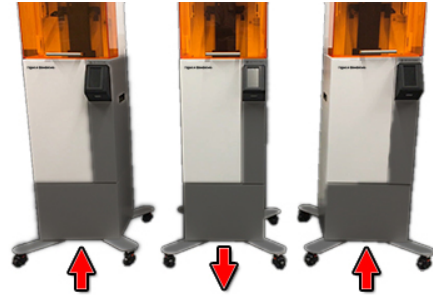

3. To nest from left to right (facing the printers) position the printer on the left such that the front-right foot can roll over and clear the front-left foot of the printer on the right.
4. Slowly move the left printer into place, backing the front-right foot as far back as it can go.
5. From here, move the printer to the left until the casters on the two front feet almost touch. Please see the video clip at the right for a visualization of the proper technique.



6. To nest the from right to left, you will follow the reverse of Steps 3-5. Facing the printers, position the printer on the right such that the front-left foot can roll under the front-right foot of the printer on the left.
7. Slowly move the right printer into place, pushing the front-left foot as far forward as it can go.
8. From here, move the printer to the right until the casters on the two front feet almost touch. Please see the video clip at the right for a visualization of the proper technique. See the clip below for a closer look and a different angle.



9. Ensure that all printer doors can open freely.
10. Level all printers according to the section [Level the Printer on Pedestal](#).
11. To un-nest the printers, simply raise all leveling feet and slide the printers apart. Re-level all printers by themselves before printing on any of them.

6.8 Figure 4 Standalone Install Carbon Filter

Unscrew the carbon-filter bracket from the printer. Remove carbon filter from its packaging and install it in the printer, as seen in the section [Change Carbon Filter](#) .



6.9 Figure 4 Standalone Turn Printer On



Tip: It may be useful to bundle the power cable and Ethernet cable together with cable ties, and secure them in place, to prevent a tripping hazard.



Note: If the printer does not power on, test the power outlet where the printer is plugged in with something you know works, such as a phone charger. Ensure the power cable is completely inserted in both the power inlet and wall outlet. Ensure that any power strip or UPS the printer is plugged into is turned on. If you have tried all these options, and the printer will not turn on, contact 3D Systems Service.



Electrical Shock: Be sure that the power switch is in the "0," or "off," position before plugging in the printer.



Electrical Shock: Use the power cord that has been supplied with the printer. Using a different power cord could cause electrical malfunction and damage to the equipment.

Turn the Printer On

The power switch and power inlet for the Figure 4 Standalone is on the back-left side of the printer.

1. Plug the power adapter into the power inlet on the printer. Plug the other end to a wall outlet.
2. Flip the power switch to the "I" position to turn the printer on.



Connect the Printer to the Internet

Plug your Ethernet cable into the Ethernet inlet on the back-right of the printer, as shown.



Note: Be sure to use the Ethernet cable that came packed in with the printer, as it has been tested to work with the printer. Alternatively, an 802.11n WiFi bridge >300Mbps may be connected to Ethernet port.



Note: An offline setup for your printer is available upon request. Contact your reseller for more information.



Ensure the Catch Tray is Installed

The catch tray will come installed in the printer. If it is not installed, contact your reseller immediately. If this is your first time printing, remove the catch tray from the printer and ensure that the protective film has been removed from both the bottom and top of the glass plate. The films should have been removed before shipping to you; but you must perform this check to ensure successful printing.

After you've ensured that there is no film on the top or bottom of the glass, you must reinstall the catch tray, as it must be present prior to printing. This is because:

1. It shields the lower print chamber from resin. If resin gets on the components of the lower print chamber, it can cause irreversible damage to the print engine.
2. The printer is expecting to project UV radiation through the catch tray's glass. If the glass is not there, you risk over-curing of printed parts.
3. There is a sensor on the catch-tray rail that can tell if the catch tray is fully seated. If the sensor sees no catch tray, the machine will not allow you to print. Ensure you push the catch tray all the way back to satisfy the sensor.

Please see the section [Clean/Replace the Catch Tray](#) for installation instructions.



6.10 Figure 4 Standalone Printer Activation

You can activate your printer by going to support.3dsystems.com/figure4standalone and clicking the Printer Activation link.



CAUTION: It is vital that you register your printer to activate your Service warranty.

6.11 Figure 4 Standalone Connect Printer to WiFi with Router

While the printer does not have embedded WiFi, you can connect the printer to WiFi via third-party products. 3D Systems recommends the [TP Link Travel Router](#). This procedure will explain how to set up your printer with this WiFi solution. You may need to consult with your network administrator for assistance.



Note: 3D Systems does NOT provide technical support for the TP Link Travel Router. If experiencing issues, contact the manufacturer here: <https://www.tp-link.com/us/support/>. Also, the following page lists many helpful troubleshooting steps: <https://windowsreport.com/wi-fi-repeater-wont-connect/>.

1. Set the switch on the side of the router to AP/Rng Ext/Client.



2. Connect your computer to the TP Link Travel Router via Ethernet (preferred) or WiFi:

a. Connect your computer, tablet, or smartphone to the router's WiFi. The network name is printed on the product label on the back of the router.

b. In a browser, go to <http://tplinkwifi.net/> . The username is "admin". The password is "admin".



3. Go to Quick setup and click Next.

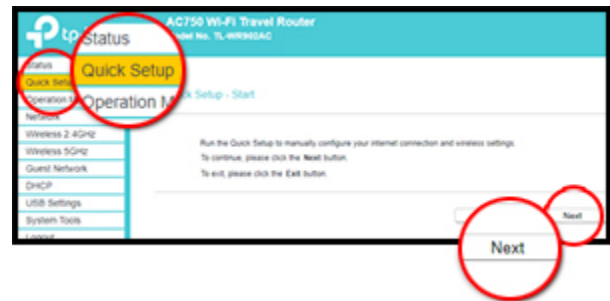

4. Under Operation Mode, select Client. Click Next.

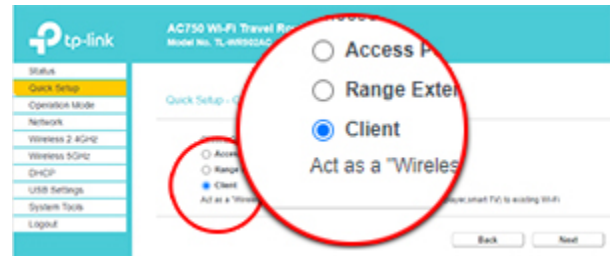

5. Under AP List, select Connect on the WiFi network to which you wish to connect.



a. Enter the password for the selected network and click Next.

b. Under Network Settings, click Next.

c. Under Review Settings, click Finish.



6. The router will reboot. Once this occurs, reconnect to the router via <http://tplinkwifi.net/> and go to DHCP.
 - a. Set the IP Range for the device to provide.
 - b. Set the Default Gateway to the master DHCP server on the network.
 - c. Set the DNS Server and Secondary DNS Server to the same as on the network. (Consult another device on the network for these values.)

7. Save the settings and reboot the device. Once this occurs, connect the device to the printer and power on the printer.

8. Connect the USB power cord between the router and the printer USB port on the right side.

9. If connecting multiple printers, skip to Step 13. If connecting only one printer, connect an ethernet cable between the router and the ethernet port on the back of the printer. Skip to Step 14.



Note: If you choose to use the USB port on the printer for router power, it will be more difficult to use a USB drive to update firmware or upload build files. In this case, you have the following options:

- Send print jobs/firmware over WiFi via 3D Sprint.
- Use a USB charger for router power.
- When uploading jobs via USB drive: disconnect the router temporarily, upload the update/build file, and then reconnect the router power.



10. If connecting multiple printers to WiFi:

- a. Set the switch on the side of the router to AP/Rng Ext/Client.
- b. Connect the USB power cord between the router and the printer USB port on the right side. You can also use the included USB power adapter.
- c. Connect an ethernet cable between the router and your ethernet port switch.
- d. Connect ethernet cables from your ethernet port switch to each printer.

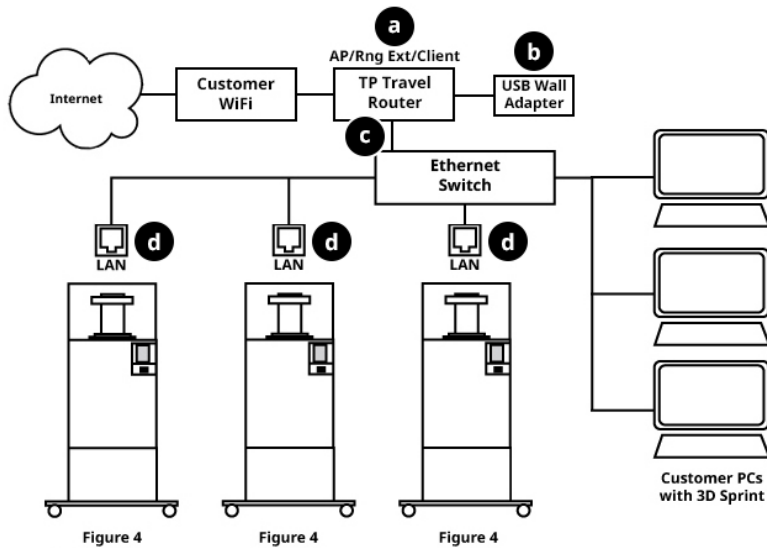

11. In 3D Sprint, search for the printer by its new IP address and connect to it.

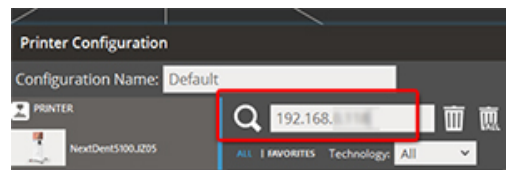

7 FIGURE 4 STANDALONE SYSTEM REQUIREMENTS AND SETUP

System Requirements

Included with the system is the part-preparation (3D Sprint™) software. This application provides part preparation and part building functionality. The 3D Sprint software is installed on a separate, customer-supplied computer. The following page contains the minimum computer configuration requirements for the 3D Sprint computer: https://support.3dsystems.com/s/article/3D-Sprint?language=en_US. Scroll down and click the 3D Sprint System Requirements link.

7.1 Figure 4 Standalone Install 3D Sprint Software



Note: 3D Sprint software is always subject to updates. An announcement, along with release notes, will accompany a new software-version release.

Please see the [Software Downloads](#) page for information on downloading/installing 3D Sprint. Before installing 3D Sprint, you may have to update some settings on your computer and graphics card. Please read the 3D Sprint Installation Guide for procedures on this and for full installation instructions.

7.1.1 Set Up Printer On Network

An offline setup for your printer is also available. Contact your reseller for more information. Follow the instructions below to set up your printer on your network.

1. Open 3D Sprint. If the Printer dialog box is not already



open, click the **PRINTER** icon in the upper-left-hand corner (1).

2. Click the magnifying glass icon to find the printer on your network. If this fails, enter the printer's IP address and press Enter. The IP address can be found on the printer's touch screen on the Settings tab (below).

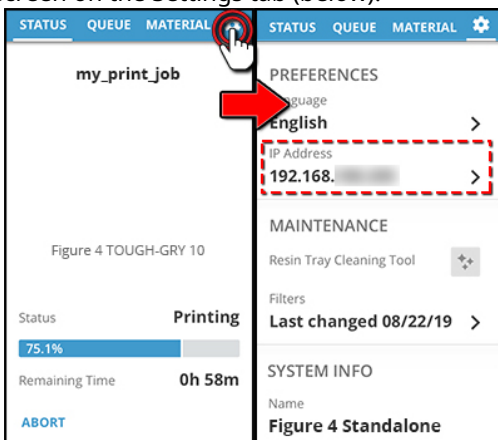

3. Click the icon that the software found for your printer.



Note: You must make the printer's IP address an exception on your network's firewall.

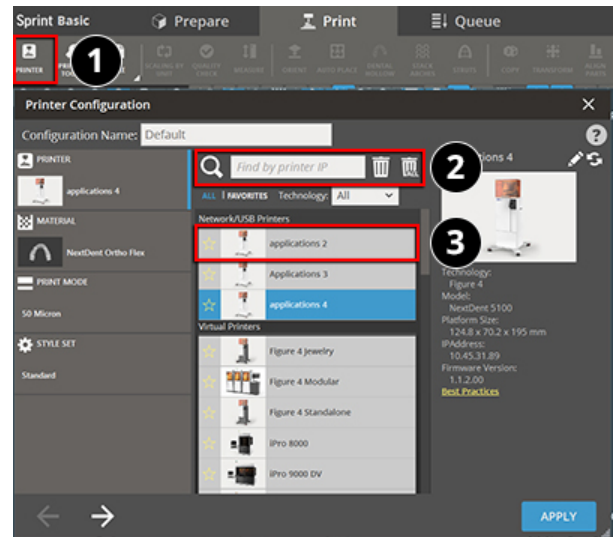

4. Select the print material you will use in your build.

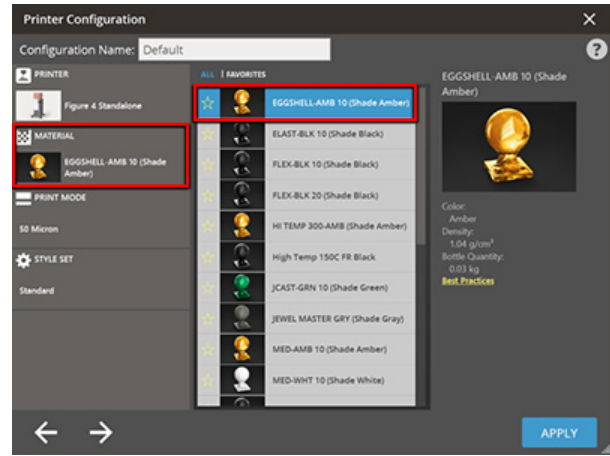

5. Select the print mode you will use in your build.

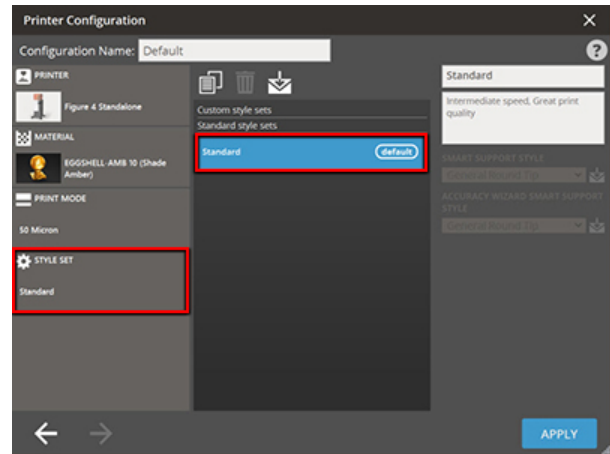

6. Select the build style you will use in your build.

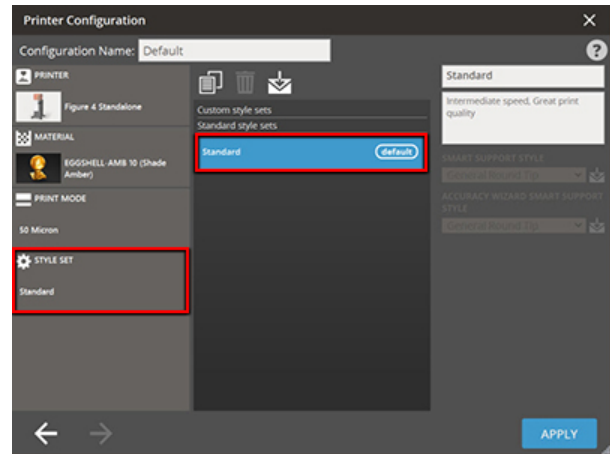

7.2 Figure 4 Standalone Accuracy Wizard

For each Figure 4 material, the Standard print mode in 3D Sprint is designed to give you accurate prints right out of the box. Please use the Standard print mode first and foremost to achieve part accuracy. However, if after measuring your parts you find that you have issues achieving accuracy, you may use the Accuracy Wizard in 3D Sprint to troubleshoot such issues.

Each Figure 4 Standalone printer will vary slightly in accuracy. If you have multiple printers, you will need to set the accuracy for each one separately. To do this, click the Printer icon in the upper left, select each printer one-by-one, and run the steps in this section for each. Additionally, you will need to run the wizard for each Material/Build Style combination you use.



Note: You will need calipers or a micrometer for this procedure to measure printed parts. Best Practices for using calipers on printed parts is demonstrated [here \(advance the video to 2:38\)](#).

1. Click the Load Reference button to load the accuracy models that will be printed.

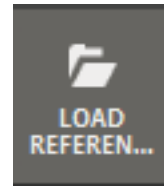

2. Click the Build Style button.

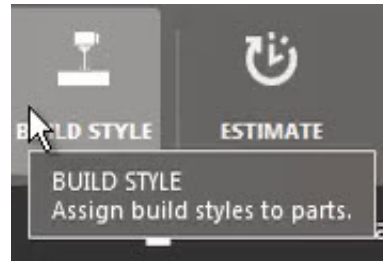

3. In the Build Style window, click the Scale & Offset Wizard button.

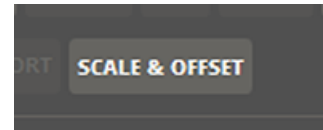

4. In the Wizard, click Save Reference Build File. Name the file and save it in the desired location. The file will be output as a .f4x file that already has supporting architecture and the correct print orientation.

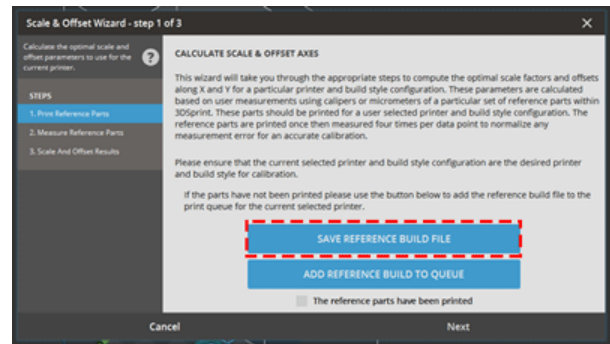

5. If you are connected to the printer, click ADD REFERENCE BUILD TO QUEUE. The file that you created will show on the touch screen in the printer's queue

6. Run the printing process, as outlined in the section [Start Printing](#) . This will print four parts that look like the models at the right. They should be roughly (clockwise from top-left) 13x10mm, 18x15mm, 23x20mm, 28x25mm. The dimensions and x/y axes will be printed on the part. Post-process the parts as in the section [Post Processing](#) .



Note: Some printer configurations will print five models. Be sure to include this model's measurements in future Steps in the wizard.

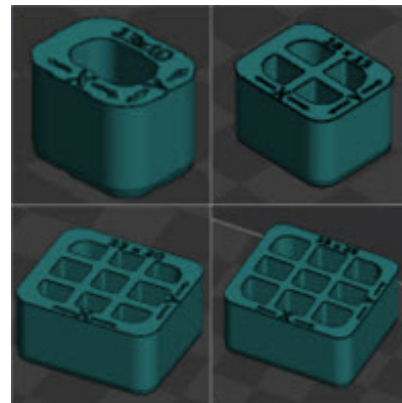

7. Open 3D Sprint again and click the Scale & Offset Wizard button to open it. This time, instead of saving a reference build file, you will:

- Check the box next to The reference parts have been printed.
- Click the Next button.

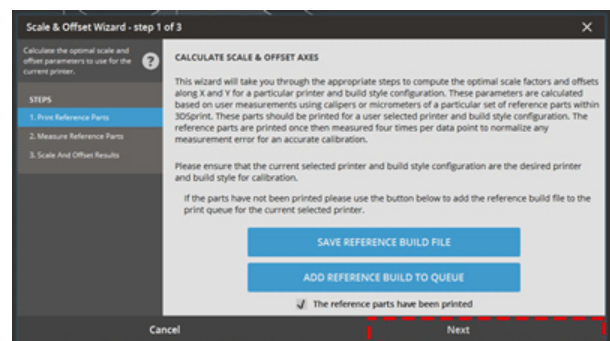

8. Measure the parts printed in Step 6 with calipers or a micrometer in the X and Y directions (Refer to [this video](#) , at timestamp 2:38, for proper caliper usage). You will measure the parts four times each in X and Y and input your measurements in the fields in the wizard that correspond to the part you are measuring. You will notice that every time you enter a value, the number in the "Average" column updates to show you the average of your measurements.

REFERENCE PART	AXIS	NOMINAL	AVERAGE	MEASUREMENTS			
				1	2	3	4
	X	13 MM	12.9625 MM	13	12.9	12.95	13
	Y	10 MM	9.965 MM	10	9.95	9.97	9.94

9. Repeat this process for each of the models and click Next when you are finished.

10. You will then see the results screen, which will show you how much the printer will now offset builds with this build style. It also shows you the scaling corrections as a percent. Click the Apply button to add this scaling to your new build style (see Step 12).

AXIS	OFFSET	SCALE
X	-0.0029 mm	100.2305
Y	0.0256 mm	99.9251

11. You will now be able to select this style from the Build Style menu going forward, allowing you to build with these scale factors at any time.

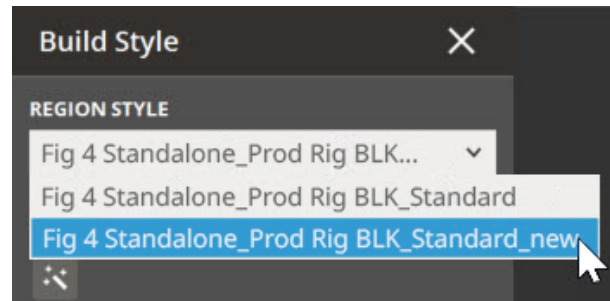

12. Remember that the Build Style is tied to the print material you are using. If you use a different print material on another print job, you will need to run this wizard again for that material. The software will automatically create/name the new build style; but you can click the Rename button to rename it.

Scaling Factor X	100.2305 %
Scaling Factor Y	99.9251 %

13. When you select this build style in the future, you can verify that it is the style with scale factors applied by looking at the Scaling Factor fields in the Build Style window.

14. Click File > Save to save your work.

15. At any time, you can verify that your accuracy values are still valid by running the verification .f4x file again. Go to Reference Builds > Load Reference Build File. This will automatically place the reference build parts onto the platform with proper supports and orientation.

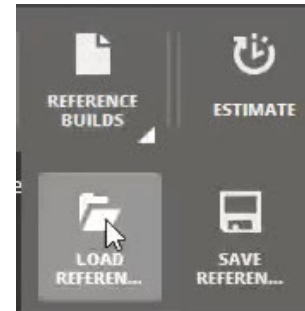

16. Click the Add to Queue button to send the .f4x file to the printer.

17. Run the printing process, as outlined in the section [Start Printing](#) . This will print the four parts from Step 15. The dimensions and x/y axes will be printed on the part. Post-process the parts as in the section [Post Processing](#) .

18. Use your calipers or micrometer to measure the parts. If they are not accurate, run Steps 8-10 once more.

7.3 Figure 4 Standalone 3D Sprint Additional Documentation

Click the icon, or press F1, in 3D Sprint for information on:

- Adding a new printer
- Adding a virtual printer
- Removing a printer
- Choosing a printer for a print job
- Updating firmware

- Sending a print job to the printer
- User Interface explanations

8 FIGURE 4 STANDALONE OPERATION

The following sections will guide you through:

- Touch Screen Interface
- Preparing and Installing the Resin Tray
- Preparing and Installing the Print Platform
- Beginning a Print Job
- Changing the Air Filter and Carbon Filter

8.1 Figure 4 Standalone Touch Screen Overview

The Figure 4 Standalone has a touch-screen-based Graphical User Interface (GUI), which is used to control the actions of the printer and adjust printer settings. Please use the following guidelines when using the GUI.



1. The touchscreen is a 4.3" LCD PCAP Capacitive Touch Screen, meaning that it registers an input whenever something holding an electric charge (like fingers) touches it. Touch input has been tested to work with lab-quality, powder-free gloves; however, you should ensure that you do not touch the screen if you have recently handled uncured resin or partially cured printed parts. This is to keep the complete functionality of the screen intact and to not contaminate it.
2. If resin does get on the screen, clean immediately with IPA and a nonabrasive cloth.
3. To wipe fingerprints off the touch screen, use a microfiber cloth.
4. Do not attempt to remove the touch screen or its casing from the printer.
5. If the touch screen becomes damaged to the point of not functioning properly, cease printing and contact 3D Systems' Service.

The GUI has three tabs with different functionality:

1. Status
2. Material
3. Settings

8.1.1 Status Tab

When you have print jobs in your 3D Sprint print queue and there is a material type loaded in the printer's memory, the status screen will look like this:

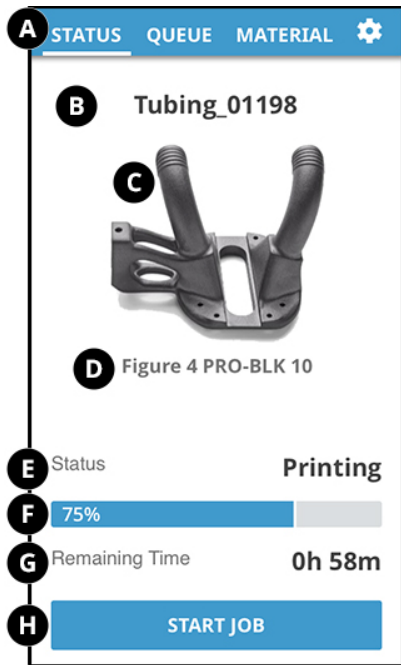

- A Status Tab - Tap this tab at any time to return to the "Status" screen.
- B Build File Name - The name of the build file sent over from 3D Sprint.
- C Print Preview - Shows the 3D model currently being printed
- D Current Resin - This is the resin that is currently loaded on the printer.
- E Status - The text shows the current state the printer is in
- F Progress Bar - Shows the percent complete of the current print job
- G Time Estimated - Time the printer should take to build the current job. This changes to Time Remaining when the job is being printed.
- H Start Job Button - Tap this button to start the print setup process

First Time Turning Printer On

When you first power on the printer, it will not have any pending jobs or print material loaded. So the status screen will appear like the image at the right. At this point, you should queue print jobs in 3D Sprint and add print material either during the print process or from the Material tab.

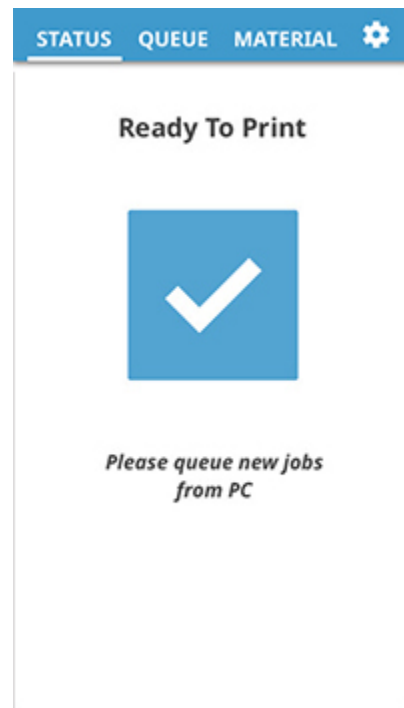

8.1.2 Queue Tab

The Queue Tab allows you to view the print queue, which shows the current print job and all pending print jobs. It also allows you to move and delete queue items. The default queue screen will simply show a list of jobs. Hold down on a job to bring up the queue-controls seen below.

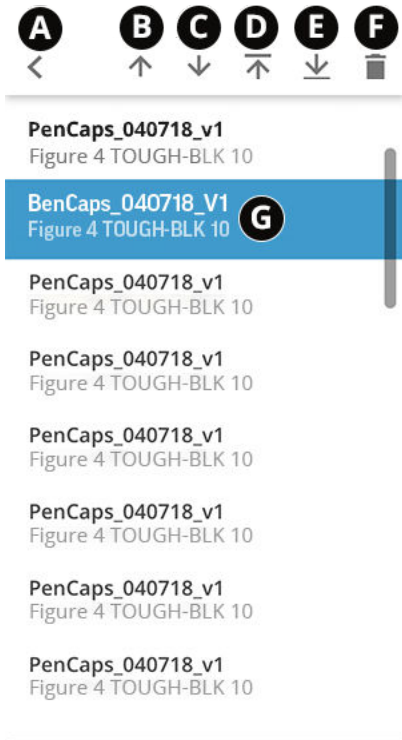

- A** Back - Tap this button to go back to the default queue screen.
- B** Move Up - Tap this button to move the job one space up in the queue.
- C** Move Down - Tap this button to move the job one space down in the queue.
- D** Move to Top - Tap this button to move the job to the top of the queue.
- E** Move to Bottom - Tap this button to move the job to the bottom of the queue.
- F** Delete - Tap this button to delete the job from the queue.
- G** Selected Job - The job highlighted in blue is the job that is currently selected for moving/deleting.

8.1.3 Material Tab

The Material Tab contains information on the material that is currently loaded in the system for printing, and also allows you to change the material you wish to print with. However, you do not have to use this screen to change materials, as the printing process gives you the opportunity to do so. The printer will keep track of how much material is left in each bottle of material that has been scanned to the machine. It will also keep track of the expiration dates of your materials.



- A** Material Tab - Tap this tab to access the menu and its options
- B** Material Name - The name of the material that is currently set for printing appears here. While the printer will keep track of the status of multiple bottles, the printer may only be set up to print with one bottle at a time. See the section [Add/Change Material and Scan Bottle](#) for more information.
- C** Material Part Example - This display demonstrates what a part printed with this material could look like.
- D** Lot Number - Also called the "batch number," this refers to the batch of material that your bottle was sourced from.
- E** Exp. Date - The expiration date of the material. After this date, the material is no longer certified to print parts used as medical devices.
- F** Change Material - Please see the section [Add/Change Material and Scan Bottle](#).

8.1.4 Settings Tab

Tap the IP address on the Settings screen to enter the Network Settings screen.

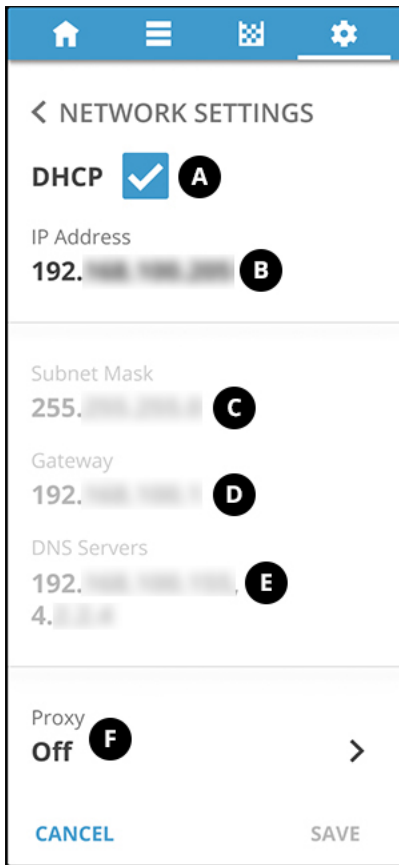

A DHCP - a network protocol that enables a server to automatically assign an IP address to a computer from a defined range of numbers (i.e., a scope) configured for a given network. Uncheck this box to enable editing of the IP Address, Subnet Mask, Gateway, and DNS Servers.

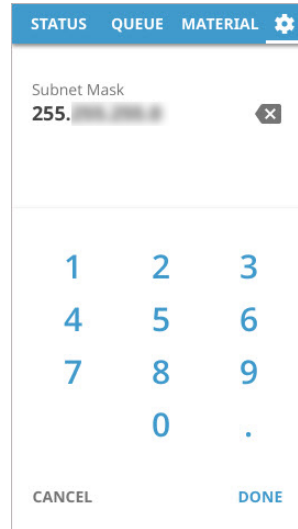

B IP Address - The numerical address given to your printer on your network. For display only. This number cannot be changed through this interface.

C Subnet Mask - hides, or "masks," the network part of a system's IP address and leaves only the host part as the machine identifier. Contact your network administrator if there is a need to change this number.

D Gateway - a router interface connected to the local network that sends packets out of the local network. For display only. This number cannot be changed through this interface.

E DNS Servers - the internet's system for converting alphabetic names into numeric IP addresses. For display only. This number cannot be changed through this interface.

F Proxy - Opens the [Proxy](#) screen for configuring a proxy server

8.1.4.1 Network Settings

Tap the IP address on the Settings screen to enter the Network Settings screen.

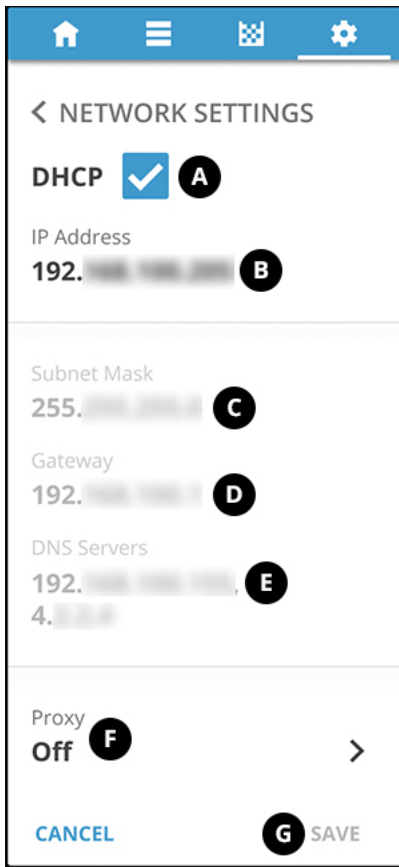

A DHCP - a network protocol that enables a server to automatically assign an IP address to a computer from a defined range of numbers (i.e., a scope) configured for a given network. Uncheck this box to enable editing of the IP Address, Subnet Mask, Gateway, and DNS Servers.

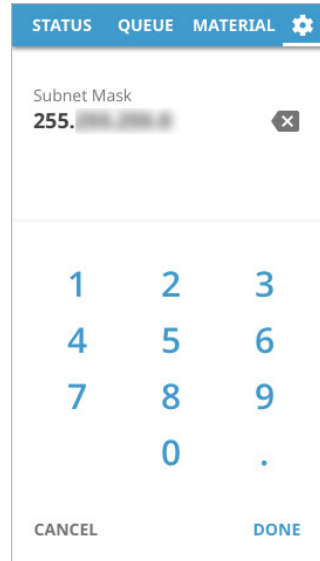

B IP Address - The numerical address given to your printer on your network. For display only. This number cannot be changed through this interface.

C Subnet Mask - hides, or "masks," the network part of a system's IP address and leaves only the host part as the machine identifier. Contact your network administrator if there is a need to change this number.

D Gateway - a router interface connected to the local network that sends packets out of the local network. For display only. This number cannot be changed through this interface.

E DNS Servers - the internet's system for converting alphabetic names into numeric IP addresses. For display only. This number cannot be changed through this interface.

F Proxy - Opens the [Proxy](#) screen for configuring a proxy server

G Save - This will become an active button when changes are made to settings.

8.1.4.1.1 Network Diagnostics

If you experience network-connection issues with your printer, you can go to Settings > Network Diagnostics to view a screen with basic connection information. The screen shows which networks the printer is currently connected to. A blue dot next to the network indicates a regular connection, while a red dot indicates a connection issue.

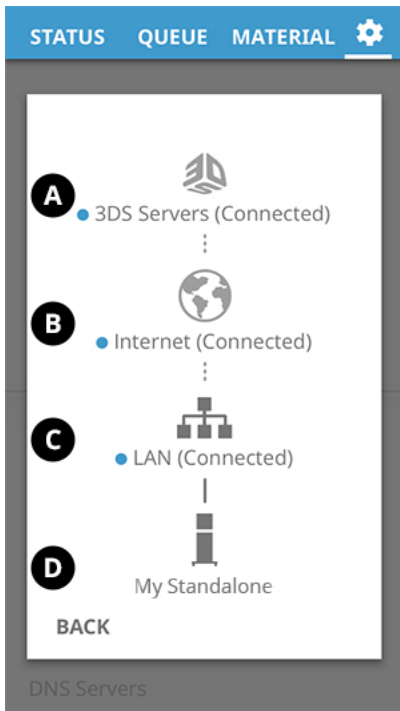

- A** 3DS Servers - The printer talks to this network to confirm print-material information. The printer can only connect to these servers with an active internet connection.
- B** Internet - A red dot here does not necessarily indicate a connection issue, as it may be your preference for your printers to not be online. Contact your network administrator for your setup's details.
- C** LAN - The printer talks to this network to send information back and forth to/from 3D Sprint.
- D** Printer - This icon simply serves as a reminder as to the printer's name.

8.1.4.1.2 Proxy

If you your printer to connect to the internet via a proxy server, you can go to Settings > Network Settings > Proxy. The screen has fields you will need to fill in with your proxy server information.



- A** Proxy Toggle - Turns the proxy connection on/off
- B** IP Address - Public IP address of printer
- C** Port - Port printer is using for public connection
- D** IP Address - Proxy connection IP address
- E** Port - Port printer is using for proxy connection
- F** Save - This will become an active button when changes are made to settings.

8.1.4.2 Firmware Updates

There are two ways to update the printer firmware:

- Update Installer
- Through the 3D Sprint interface

The following sections describe these processes.

8.1.4.2.1 Update Printer Firmware via Update Installer

Whenever a new firmware file is released for the printer, a desktop installation file will be posted in the [Software Downloads](#) section of the printer website. Follow the instructions below to download and install this update.



Note: Both your personal computer and the printer must be on the same network to update the printer's firmware using this method. The update cannot be installed during printing.



CAUTION: For users on firmware 1.1.1, it is recommended to instead update firmware via 3D Sprint.

1. Visit the [Software Downloads](#) page and download the Latest Firmware Installer for Network Installation.



2. Locate the downloaded zip file on your PC. Unzip the folder and open the Figure_4_Update_Installer.exe file. You will see the screen at the right.



Note: You may receive a warning about opening a file from an unknown publisher. This is normal. Tell the window to "open anyway."



3. Enter the IP address of your printer (found on the Settings tab) and click Install Update. The installation will take up to 15 minutes. If on a VPN, the installation could take longer, depending on connection speeds.



4. The update will begin to automatically install on the printer. Do not unplug, restart, or perform any tasks on the printer. When finished, you will see the screen at the right on the Update Installer. You may now close the installer. To install the update on another printer, re-open the Update Installer.



5. On the printer, ensure that you see the "Update Complete!" screen at the right. If you do not see this, navigate to the [Settings](#) tab to check if the firmware version has been updated. If it has not, perform the upgrade again. If the issue persists, contact your reseller.

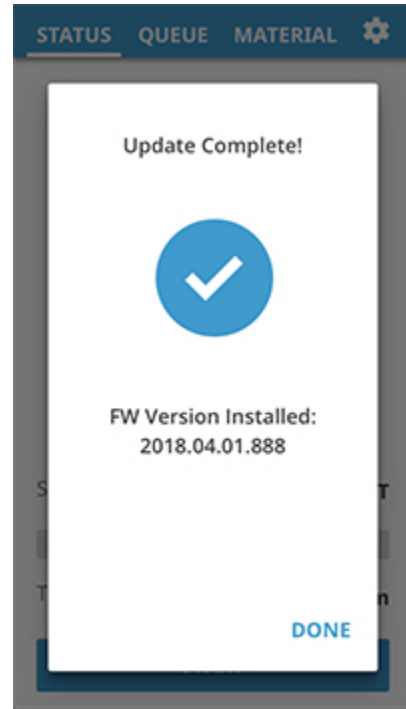

Your firmware has successfully been updated!

8.1.4.2.2 Update Printer Firmware via 3D Sprint

Whenever you open 3D Sprint, as long as the Figure 4 Standalone is set as your default printer, the system will always check to see if your printer has the most up-to-date firmware. If the firmware is not up-to-date, Sprint will show you a popup prompt to update it. Click the button to update. If you choose to update the firmware at a later date, please close the popup and follow the instructions below when you are ready to update.



Note: You must be running >3D Sprint 2.13 to use this update method. Both your 3D Sprint computer and the printer must be on the same network to update the printer's firmware. The update cannot be installed during printing.



CAUTION: For users on firmware 1.0, it is recommended to instead update firmware via the [Update Installer](#).

1. Click the Printer Tools button.

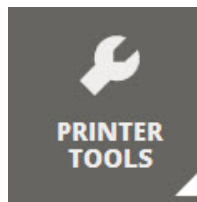

2. Click the Check for Updates button. This will either give you a popup to update the printer's firmware or a popup that will tell you that the printer's firmware is up to date.



3. If there is new firmware, click Yes to install and the update will download to your PC.

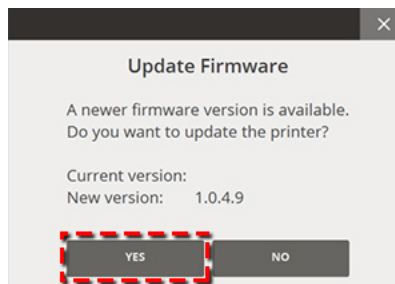

4. Click the C:\ link in the popup to locate where the file is stored, and transfer the file to the root folder of your USB drive.

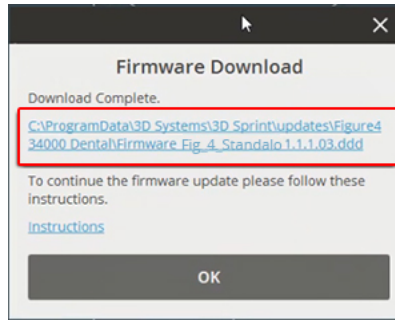

5. Plug the USB drive into your printer; and you will see the screen at the right. Tap Install.

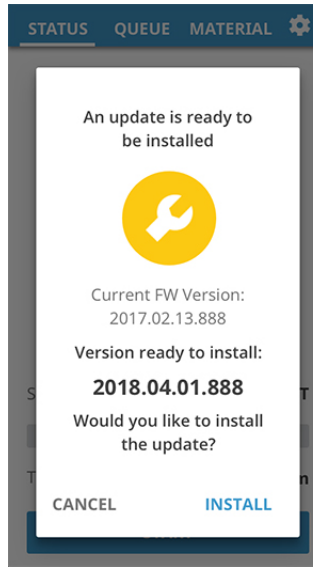

6. On the printer, ensure that you see the "Update Complete!" screen at the right. If you do not see this, navigate to the [Settings](#) tab to check if the firmware version has been updated. If it has not, perform the upgrade again. If the issue persists, contact your reseller.

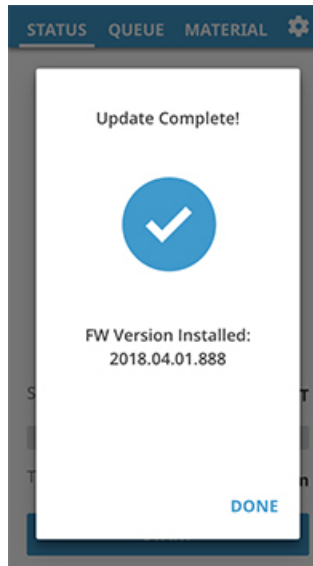

8.2 Figure 4 Standalone Prepare and Install the Resin Tray

Resin Tray Guidelines

The membrane contained within each resin tray is the most fragile component of the Figure 4 Standalone Printer. It must be handled with care. Follow all resin-tray guidelines and procedures to avoid membrane damage and failure.



HARMFUL IRRITANT WARNING: Wear protective clothing, disposable nitrile gloves, and goggles while handling the resin tray.



CAUTION: If a leak/spill occurs, do not run the machine. UV curing will harden the resin on unwanted surfaces and will make the resin very hard to remove. A nonabrasive cloth and IPA will help clean up any spilled uncured resin.



CAUTION: Failure to clean the resin tray of partially cured resin will lead to membrane failure and failed prints.

1. Expected lifetime of the resin tray is around 900 builds.
2. Do not apply pressure to the membrane. Deformations form easily and permanently, and may lead to membrane failure and degradation of print quality. Never touch the membrane with sharp objects.
3. Do not touch the membrane with bare skin. Skin oils may cause print-quality degradation.
4. Always verify that all printed parts and supports have been accounted for after a build. Be sure to inspect the resin tray for partially cured material. Cured material (also called green material) that is clear, or tiny bits of cured material may not be visible to the naked eye. If you suspect that partially cured material might be present in the tray, you must clean the tray before building again.
5. Always ensure there is enough print material in the resin tray to complete a build before starting the print job. Adding additional material during a print job is not recommended, as it would require opening the printer lid during printing.
6. With thorough cleaning of the resin tray in between builds, it is possible to use different resins in the same resin tray (not at the same time). Please see the section [Resin Tray Resin Cross-Usage](#) for information on which resins may share a single resin tray. Do not mix two or more types of resin in the resin tray. Doing so will cause both materials to become ineffective.
7. Avoid transporting a resin tray that is filled with resin so as to avoid spills. Always carry resin tray with both hands to help ensure that it does not drop on the floor. Any damage to the resin tray would mean that the resin tray needs to be replaced.
8. Do not move the printer while there is a resin tray inside that is filled with resin. Even moving the printer a few inches with resin inside can cause a resin spill.
9. Uncovered resin trays should not be left outside the Figure 4 Standalone Printer when containing any amount of print material. Material will cure when exposed to ambient light. Cured material is extremely difficult to remove from the resin-tray membrane without causing damage. If you store a resin tray containing material outside the printer, use the resin-tray garage and store the tray in a cool, dark place.
10. Resin overflow from the resin tray will be channeled into the catch tray. Discard the resin in the catch tray according to all government regulations.
11. When pouring print material back into its bottle, be sure to use a filter, as seen in the section [Clean Resin Tray](#).
12. Always ensure the resin tray is clean of uncured liquid resin and partially cured bits before each print.
13. Always ensure that the resin tray is not damaged in any way, particularly on the membrane. Resin-tray damage could cause build failure and/or resin leakage. Resin-tray damage can be: membrane puncture, dent, scratch or discoloration.

8.2.1 Install Resin Tray



Note: A print platform should not be installed during this procedure.



CAUTION: If tension system is damaged in some way, do not attempt to force any components to engage/disengage. Doing so could further damage the tension system, as well as other parts of the printer. Contact 3D Systems Service immediately.



Wear Protective Gloves: ALWAYS WEAR 100% nitrile gloves whenever reaching inside the print chamber.

1. Open the front door of the printer

2. Push in the tension-arm release lever on the front of the tension arm and lift up the tension arm. The arm will stay in place in the up position.

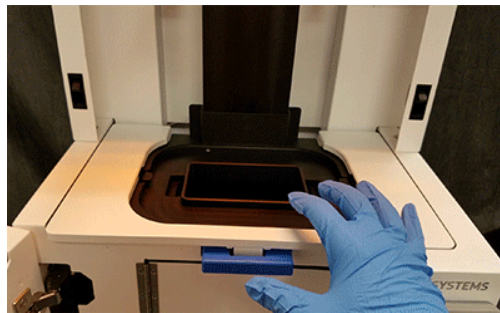

3. Carefully lower the resin tray into place, concave side up, as seen at the right. It should fit snugly in the holder on the chassis.

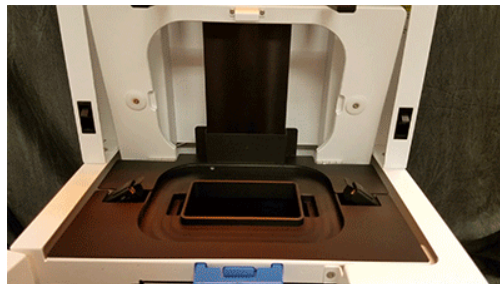

4. Apply tension to the membrane by flipping down the manual tension arm until the release lever locks it in place.



CAUTION: Major build defects and/or membrane failure will result if a print is attempted on an untensioned membrane.

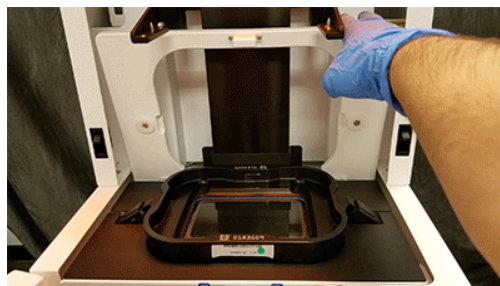

8.2.2 Add-Change Material and Scan Bottle

Once a material type has been loaded, this is the material that the printer is expecting for the next print job. But you may wish to change the type of resin you are using. Most of the time, you will be changing the material as part of the [printing process](#). However, you can also tap the Change Material button at the bottom of the Material tab home screen to change the material type to be used on your next print. You can also use this screen to add print material for the first time. If you have not yet activated your printer, you must do so in order to get through the following steps. Please see the section [Printer Activation](#) for more information.



Note: The screens in this section will be slightly different depending on whether you are changing the material type or adding material for the first time.

1. On the Material tab, tap the Change Material button.



2. The scanner below the touch screen will be activated and you will see a screen like the one at the right. Hold your material bottle's QR code in the path of the scanner such that the center dot is in the middle of the QR code (see image below).



CAUTION: The printer keeps track of how much resin is used from your bottle. Ensure you are pouring from the same bottle you scanned. Using one bottle to scan and another to pour from will result in the printer thinking your bottle is empty after a certain amount of pours.

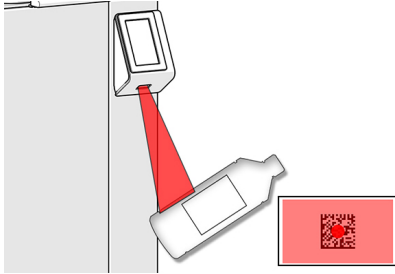

3. If the scan is successful, you will see the Bottle Found screen, like the one at the right. If the scan is not successful, this could be for a number of reasons, which are outlined in the section [Printer Error Messages](#).



4. Remove the print platform and resin tray, cleaning them both, as per the sections [Clean Print Platform](#) and [Clean Resin Tray](#).

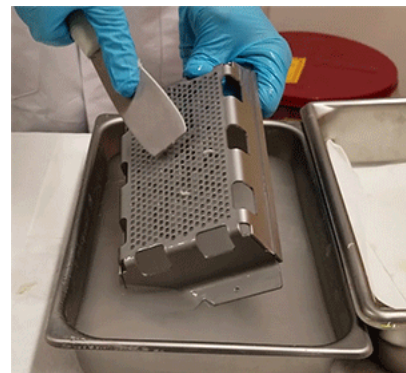

5. After removing the resin tray, label it on the outside with an identifying number, letter, or word(s) to let you know which material was in it before.



6. If the catch-tray glass has a large amount of spilled resin on it, you must dispose of it according to all government regulations and replace it with a new catch tray. If it has no resin, or just a few resin spots on it, clean the glass with >90% alcohol solvent on a nonabrasive cloth, according to the section [Clean/Replace the Catch Tray](#).

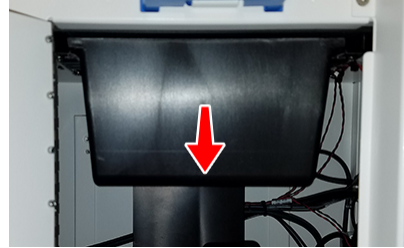

7. Reinstall the print platform.

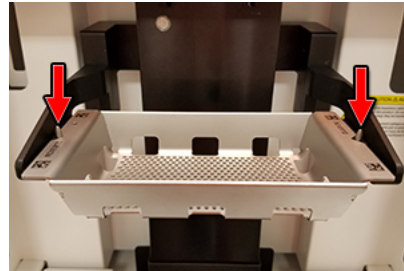

8. Install a new resin tray or reinstall the cleaned old one, as per the section [Install Resin Tray](#).

9. If this is a new resin tray, label this tray with the same naming convention used in Step 5.



10. On the Material tab, your new material will be loaded. [Fill the tray](#) with the new material and check the boxes on the screen. Tap Confirm.

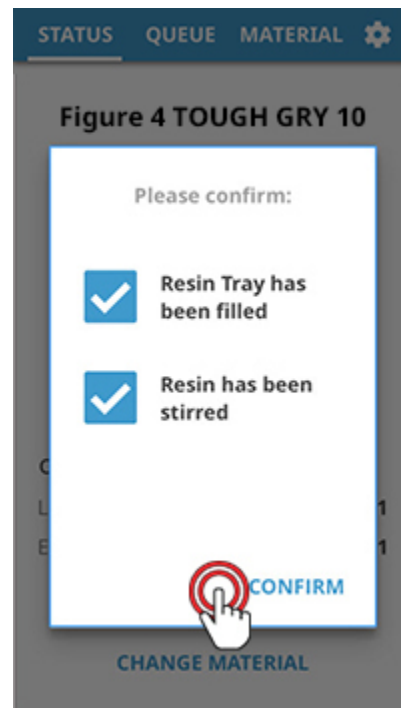

You are now ready to perform the print process with a new material.

8.2.3 Resin Tray Material Cross-Usage

You may clean the resin tray with >90% alcohol solvent between builds, enabling you to use different resins in the same resin tray (not at the same time). However, if a clear resin is poured into a tray that previously had a pigmented resin, it could result in undesirable coloring of the printed part. Because of this, if you intend to use the whole family of Figure 4 print materials, you will need a minimum of two resin trays for your Figure 4 Standalone Printer. The chart below shows which resins can share the

same resin tray (provided that you have cleaned them with >90% alcohol solvent in between uses), with the minimum two trays indicated as trays 1 and 2. You may desire to use more than two trays for your purposes. Mark your resin trays with letters or numbers to help you remember which tray is which.

Tray 1	Tray 2	Tray 3
Figure 4 TOUGH GRY 10	Figure 4 MED-AMB 10	Figure 4 RUBBER-BLK 10
Figure 4 TOUGH GRY 15	Figure 4 MED-WHT 10	Figure 4 RUBBER-65A BLK
Figure 4 JCAST-GRN 10		
Figure 4 ELAST-BLK 10		
Figure 4 FLEX-BLK 10		
Figure 4 TOUGH-BLK 20		
Figure 4 PRO-BLK 10		
Figure 4 HI TEMP 300-AMB		
Figure 4 FLEX-BLK 20		
Figure 4 EGGSHELL-AMB 10		
Figure 4 JewelMaster-GRY		
Figure 4 Rigid White		
Figure 4 High Temp 150C FR Black		
Figure 4 TOUGH 65C BLACK		
Figure 4 TOUGH 60C WHITE		
Figure 4 RIGID GRAY		
Figure 4 Rigid 140C Black		

8.2.4 Mixing, Stirring, and Curing Chart

Before pouring any Figure 4 resin in the resin tray, you must mix the resin bottle according to the chart below. Before printing again with those resins, you must stir the resin in the resin tray using the Resin Mixer. Stirring the material in the resin tray serves two purposes: 1. Ensuring a good resin mixture; and, 2. Ensuring there is not debris in the resin tray, such as partially cured particulates.

Material Stirring and Curing Chart



CAUTION: Failure to sufficiently mix resins according to this chart may result in color deviation and/or print failure.

The chart below serves as a quick reference for resin-bottle mixing time on the NextDent LC-3DMixer, resin stirring time when resin is in the resin tray, and part-curing time in the LC-3DPrint Box.

For part-washing times, please see the section [Cleaning Chart](#).

For part-drying times, please see the section [Dry the Build Parts](#).



Note: If your print-material bottle has been sitting unused for more than one month, treat it like a new bottle and mix it according to the "brand new bottle" column below.

NAME	BOTTLE SHAKING TIME BEFORE MIXER USE (1, SEE NOTE BELOW)	BOTTLE MIXING TIME REQUIRED (LC-3DMIXER)		STIRRING TIME REQUIRED (IN RESIN TRAY)		CURING TIME IN LC-3DPRINT BOX
		Brand new bottle	After first use (2, see note below)	In tray less than 3 hrs	In tray more than 3 hrs	
General Purpose						

NAME	BOTTLE SHAKING TIME BEFORE MIXER USE (1, SEE NOTE BELOW)	BOTTLE MIXING TIME REQUIRED (LC-3DMIXER)		STIRRING TIME REQUIRED (IN RESIN TRAY)		CURING TIME IN LC-3DPRINT BOX
Figure 4 Tough Clear (3, see note below)	n/a	n/a	n/a	30 secs.	30 secs.	60 min.
Figure 4 PRO-BLK 10 (3, see note below)	n/a	1 hr.	10 min.	30 secs.	30 secs.	90 min.
Figure 4 TOUGH GRY 10 (3, see note below)	n/a	1 hr.	10 min.	30 secs.	30 secs.	60 min.
Figure 4 TOUGH GRY 15 (3, see note below)	n/a	1 hr.	10 min.	30 secs.	30 secs.	90 min.
Figure 4 TOUGH-BLK 20 (3, see note below)	n/a	1 hr.	10 min.	30 secs.	30 secs.	90 min.
Figure 4 FLEX-BLK 10 (3, see note below)	n/a	1 hr.	10 min.	30 secs.	30 secs.	60 min.
Figure 4 FLEX-BLK 20 (3, see note below)	n/a	1 hr.	10 min.	30 secs.	30 secs.	90 min.
Figure 4 Rigid White (3, see note below)	n/a	1 hr.	10 min.	30 secs.	30 secs.	90 min.
Figure 4 Rigid Gray (3, see note below)	30 secs.	1 hr.	10 min.	30 secs.	30 secs.	90 min.
Figure 4 Tough 60C White (3, see note below)	n/a	1 hr.	10 min.	30 secs.	30 secs.	90 min.

NAME	BOTTLE SHAKING TIME BEFORE MIXER USE (1, SEE NOTE BELOW)	BOTTLE MIXING TIME REQUIRED (LC-3DMIXER)		STIRRING TIME REQUIRED (IN RESIN TRAY)		CURING TIME IN LC-3DPRINT BOX
Figure 4 Tough 65C Black (3, see note below)	n/a	1 hr.	10 min.	30 secs.	30 secs.	90 min.
Figure 4 Rigid 140C Black	See Special Considerations for Rigid 140C Black Material .					
High Temperature						
Figure 4 HI TEMP 300-AMB	n/a	n/a	n/a	n/a	n/a	90 min.
Figure 4 High Temp 150C FR Black	n/a	1 hr.	10 min.	30 secs.	30 secs.	90 min.
High Temperature and Medical						
Figure 4 MED-AMB 10	n/a	n/a	n/a	n/a	n/a	60 min.
Figure 4 MED-WHT 10	5 min. before each use, whether "brand new" or "after first use"	2.5 hrs.	1 hr.	30 secs.	60 secs.	60 min.
Elastomer						
Figure 4 ELAST-BLK 10 (3, see note below)	n/a	1 hr.	10 min.	30 secs.	30 secs.	45 min.
Figure 4 RUBBER-BLK 10 (3, see note below)	n/a	1 hr.	10 min.	30 secs.	30 secs.	90 min.
Figure 4 RUBBER-65A BLK (3, see note below)	n/a	1 hr.	10 min.	30 secs.	30 secs.	90 min.
Casting						
Figure 4 JCAST-GRN 10 (3, see note below)	n/a	1 hr.	10 min.	30 secs.	30 secs.	30 min.
Figure 4 EGG SHELL-AMB 10	n/a	n/a	n/a	n/a	n/a	90 min.

NAME	BOTTLE SHAKING TIME BEFORE MIXER USE (1, SEE NOTE BELOW)	BOTTLE MIXING TIME REQUIRED (LC-3DMIXER)		STIRRING TIME REQUIRED (IN RESIN TRAY)		CURING TIME IN LC-3DPRINT BOX
Figure 4 JEWEL MASTER GRAY (3, see note below)	n/a	1 hr.	10 min.	30 secs.	30 secs.	60 min.



Note: Ensure that you place the build in your UV curing oven in the same orientation it was printed in, as if the bottom of the oven is the print platform.

1. Pre-shaking by hand

For best printing results, some MED print materials require that you pre-shake the bottle by hand before placing it on the LC-3DMixer for the specified time. This is to ensure that sediment thoroughly mixes with the rest of the material.

2. Considerations for resin that has been sitting, unused, for over 1 month

If you have a resin bottle like this, simply treat it like a new bottle and mix it for the time specified in the "Brand-new bottle" column in the above chart.

3. For these materials only, instead of using the bottle mixer:

You may opt to mix the material bottle exclusively by hand, shaking it vigorously in an up-and-down motion. Shake it for five minutes for a new material or for one you are treating as new (see above note). Shake the bottle for two minutes for a recently used bottle.

8.2.5 Fill Resin Tray With Material



HARMFUL IRRITANT WARNING: Always handle the resin tray with care, even if you believe there is no material in it. Wearing contact lenses when handling a resin tray filled with material is not recommended. Wear 100% nitrile gloves when handling the resin tray, even if you believe there is no material in it. Be careful not to pour material outside the resin tray, or to allow material to splash outside the resin tray. Liquid material has the potential to damage electrical equipment, particularly in the lower part of the printer.



Tip: You may choose to hold the material bottle with two hands, just in case it slips out of one hand, so that you do not drop the material bottle.

Fill the Resin Tray

Before filling the resin tray, you should have completed the steps in the section [Add/Change Material and Scan Bottle](#) . If you have not done so, do so now.



CAUTION: Failure to properly switch materials will result in reduced reactivity of the new material, even when only very small amounts of different material(s) are mixed in. This will result in build failure and wasted material.

1. Before pouring the material into the resin tray, be sure you do the following:

- a. Mix the material on the LC-3DMixer (1) for the time specified for your material in the [Material Stirring and Curing Chart](#) or shake the bottle vigorously in an up-and-down motion (2).



CAUTION: Failure to sufficiently mix materials before each build may result in color deviation and/or print failure.

- b. If you are using the same material bottle as in your previous build, be sure that the print platform and resin tray are completely clean of debris (such as dust), and/or partially cured material residue.



CAUTION: Failure to clean the resin tray and print platform of debris may affect the material's reactivity and the printed part's ability to adhere to the print platform.

- c. If you are using a new bottle of the same material, but it has a different batch number than your last bottle, you must either empty the resin tray of the previous material or use a different resin tray for the new bottle. Please see the section above about mixing old and new material.

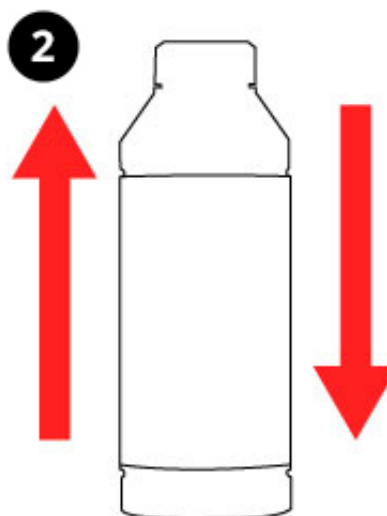

2. Before filling the resin tray with material, take note of the markings printed on the front and back.

a. The MIN mark indicates that the 5mm (0.2 in) pool in the bottom of the tray is full. Do not print if the resin level is below this line.

b. Each numbered mark indicates 100mL (3.4 fl. oz.) more of resin on top of the 5mm pool, on up to 400mL (13.5 fl. oz.).

c. The MAX mark indicates a resin level of 430mL (14.5 fl. oz.). See caution statement below.

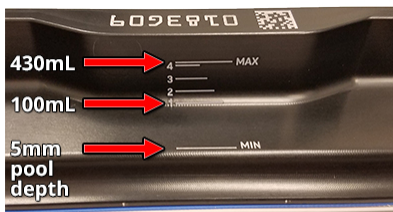

CAUTION: Do not fill the resin tray beyond 430 mL (14.5 fl. oz.). Doing so risks spilling material and/or getting material on elevator arms during printing.

3. Slowly pour material until desired height is reached. Hold the bottle low over the tray while pouring to avoid splashing.

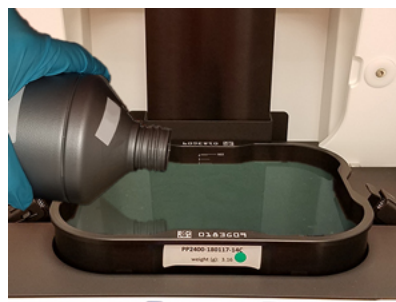

4. Close printer lid as soon as possible after pouring, so as to avoid any unnecessary exposure of the material to ambient UV light.

8.2.6 Mixing Material in the Resin Tray

Resin that is left in the resin tray between builds needs to be stirred periodically. In this case, you would use the Resin Mixer to stir the resin, as seen below. Refer to the [Material Stirring and Curing Chart](#) for information on stirring materials.



CAUTION: Failure to sufficiently mix resins before each build may result in color deviation and/or print failure.



CAUTION: Ensure that the comb is clean before each use. To clean the comb, wipe it with a nonabrasive cloth and the recommended solvent.

1. Run the comb through the resin, with the sharp end (A) facing down. Grip the comb on the indented gripper (B). Please see the images below for the proper stirring technique.



CAUTION: Do not scrape the comb's blade from side to side like a knife. Rather, move it back and forth like an ice scraper.

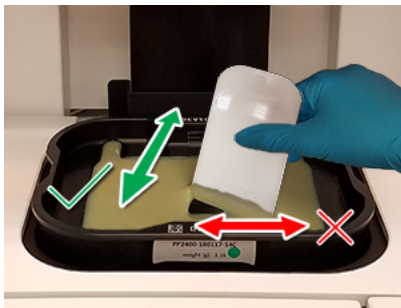

2. Holding the comb slanted, run it back and forth through the resin, careful not to put too much pressure on the resin-tray film. Do this for the time prescribed in the [Material Stirring and Curing Chart](#), or until all resin that has stuck on the resin-tray film has been scraped off. You are looking for stuck-on resin spots like that which is circled below:

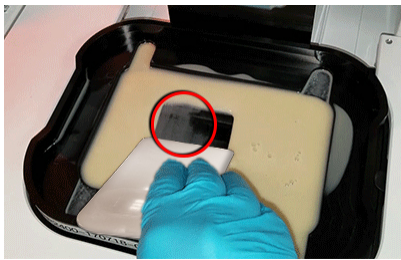

3. After stirring, allow the resin mixer to drip resin back into the resin tray and then wipe excess resin off the comb with a nonabrasive cloth.

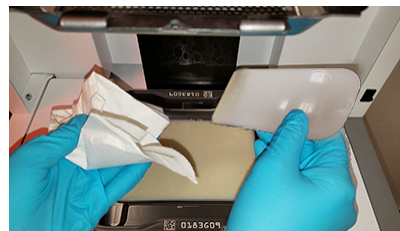

CAUTION: Putting too much pressure on the resin-tray film can dent or puncture the film, rendering the tray unusable. The film cannot be replaced by itself; if the film is damaged, the whole resin tray must be replaced.



CAUTION: Puncturing the resin tray will force a full tray's worth of print material into the catch tray. Use extra caution when handling a full catch tray.



CAUTION: If the resin tray gets punctured, discard it in the same way you would other materials that have been in contact with liquid resin.



CAUTION: Take care not to slosh resin out of the resin tray while stirring. If this happens, you will have to clean the parts of the printer that the resin got on.

4. Repeat the stirring process as indicated by the [Material Stirring and Curing Chart](#) .



CAUTION: Be sure to clean the comb with IPA between uses. Failure to do so risks mixing unstirred resin or different resin in with material currently in the resin tray.

8.3 Figure 4 Standalone Prepare and Install the Print Platform

Print Platform Guidelines

Print platforms should be treated with care in order to preserve their shape and coating. Avoid dropping print platforms. Print platforms should be thoroughly cleaned and inspected after every use to ensure print adhesion, to ensure that two different resins do not mix, and to avoid resin-tray membrane damage.

1. Remove and post-process the printed part and the print platform either together or separately, according to your purposes.
2. Once the printed part is separated from the platform, follow the instructions in the section [Clean Print Platform](#) before reusing the platform.
3. Inspect the following areas for cured resin. If cured resin is present, remove using the included Platform Scraper.
 - a. Elevator guides
 - b. Print surface - underside of print platform
 - c. Print surface holes
4. Verify flatness of the print platform. Ensure the platform has not become concave, convex, or scratched to the point of making a groove. If the platform is damaged, as discussed or otherwise, dispose of the platform. The user is responsible for determining the integrity of the print platform before using it to print.
5. Always handle the print platform with two hands, so as to prevent dropping it on the ground. A drop could cause damage to the platform, as well as get debris on it, which could contaminate the resin in the resin tray.
6. Contaminants such as dust, oils from the skin, or cured print material can cause poor print adhesion and/or resin contamination. Even if it appears there is no contamination, clear resins, or small bits of cured material may not be easily spotted by the naked eye. Because of all these factors, clean the platform as well as possible in between builds and always wear 100% nitrile gloves when handling the print platform.
7. Never attempt to move the elevator arms by hand. The elevator should only be operated via the printer's GUI.

8.3.1 Install Print Platform



Wear Protective Gloves: Always wear 100% nitrile gloves when handling the print Platform.



CAUTION: The printer will operate without a print platform installed. Ensure you install it before every print.



CAUTION: Do not leave the printer lid open for an extended time. Leaving the lid open will allow light to cure the material inside and will also allow dust/contaminates in.

1. Open the printer lid by pulling the handle on the front. It will stay open by itself once you lift it.

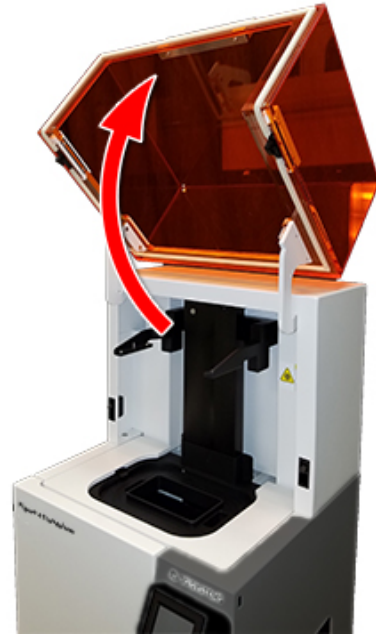

2. Verify the platform has been properly cleaned and is not visibly warped. A properly cleaned print platform will not have any residual print material or contaminants of any kind present. Special attention should be paid to the print surface (1), and elevator guides (2).

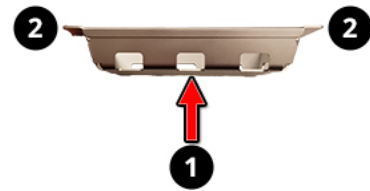

3. Also make sure the elevator is at its upper limit, or offload, position before installing the platform.

4. Install the print platform onto the elevator arms, convex side down, as seen at the right. The triangular groove on each print-platform elevator guide lines up with the cone-shaped pin on each elevator arm. Ensure the print platform is fully seated and level. Magnets will secure the platform in position. If you feel there is an issue with how the print platform is sitting on the elevator arms, do not build on the printer. Contact 3D Systems customer service.

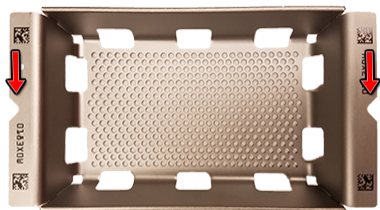
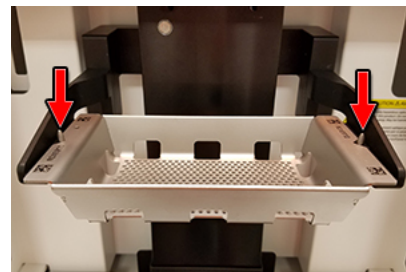

Triangular grooves

8.4 Figure 4 Standalone Start Printing

Prepare Build File in 3D Sprint

Before printing can begin, you must prepare a 3D model in 3D Sprint, slice the file, and export the sliced file to the printer.

When in the 3D Sprint Software, you can click the  icon, or press F1, for full software instructions. If you do not wish the print job over your network, please follow the steps in the section [Submit Build File via USB](#).

Printing for the First Time

If you are building for the first time on the printer, the [Quick-Start Guide](#) will walk you through running a verification build to ensure the printer is functioning normally. It is highly recommended to print this part before attempting any other builds on the printer. This build is not meant to test the printed parts for accuracy. To test accuracy, please follow the instructions in the section [Accuracy Wizard](#).



CAUTION: Do not run this test print without resin in the resin tray. It is necessary to print the part and observe part quality to ensure that the test print was a success.

Print Process

1. Once you have sent a build file to the printer from 3D Sprint, the printer's Status screen will look like the screen at the right. Tap the Start job button.



Note: If the pending print job requires a resin that is different than the one loaded on the printer, you will be prompted to take steps to change the loaded print material, as seen in the section [Change Material Before Printing](#).



my_print_job

Figure 4 TOUGH BLK 10

Status **Ready To Print**

0%

Total Time **1h 12m**

START JOB



2. The QR-code scanner below the touch screen will be activated and the printer will ask you to scan a bottle of the print material sent over in the build file from 3D Sprint. You will see a screen similar to the one at the right. Ensure you are scanning the correct material bottle and hold the bottle's QR code in the path of the scanner such that the center dot is in the middle of the QR code.

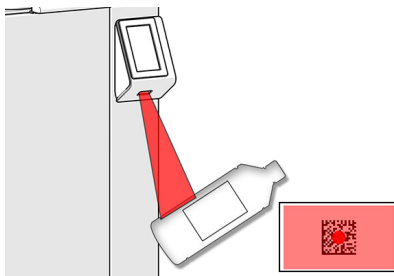

3. If the scan is successful, you will see a screen similar to the one at the right. If the scan is not successful, this could be due to a few different reasons, which are outlined in the section [Printer Error Messages](#) .



4. The printer will remind you to perform three tasks before proceeding with the print job. Tap each check box as you perform each task.

a. Empty and clean print platform, as in the section [Clean Print Platform](#) .

b. Mix the material, as in the section [Mixing, Stirring, and Curing Chart](#) . This refers both to stirring the material that is currently present in the resin tray and mixing the material that is in the bottle.

c. Fill the resin tray from the material bottle you just scanned, as in the section [Fill Resin Tray With Material](#) .

5. Tap Start Job button.

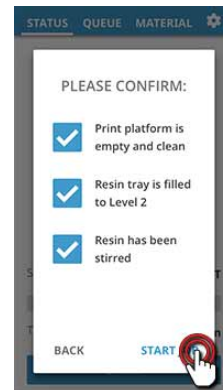
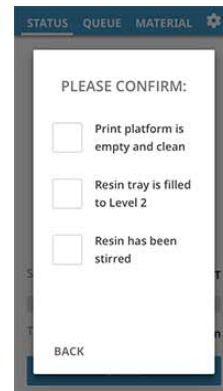

6. You will see a screen like the one at the right, with the progress bar showing the "percent complete" of the print job. You will also see a print preview of what is currently printing. You may abort the print job at any time by tapping the Abort button. Please see the section [Abort a Print Job](#) for more information.

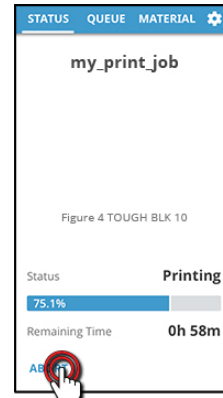

7. Once the job has completed, you will see a screen like the one at the right. Please proceed to the section [Post Processing](#).

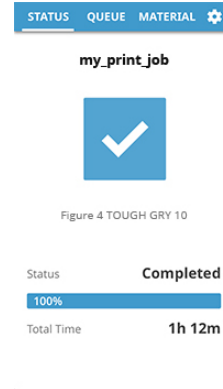

8.4.1 Submit Build File via USB

If you do not want to submit your build file over a network, you may save the build file to a USB drive and upload it to the printer. This section assumes you have prepared the build file in 3D Sprint and transferred the file to a USB device.



Note: The printer only accepts USB drives formatted in FAT32 or NTFS. If you experience issues with the printer reading your USB device, you can troubleshoot by turning the power switch on the back of the printer off, and then on again. If you continue to experience issues, contact your reseller.

1. At any time, even during printing, you may insert a USB device with .f4x or .pjl files on it. The printer will automatically look for these files and show the screen at the right if it finds them. Tap Dismiss if you do not wish to transfer USB files at this time. Tap Select Jobs to bring up a list of the build files on the USB device.



Note: If the printer finds a firmware-update file on your USB device, it will prompt you to update the firmware with that file before it shows any of the print jobs on the device. Tap "Cancel" and the printer will then show the "print jobs" screen at the right.



Note: The PXL format slices the file in 3D Sprint, which makes the job-submission process faster than submitting with the F4X format. However, the file will be optimized for the printer that Sprint was connected to at the time the file was created, while F4X can be used effectively on any of your Figure 4 Standalone printers. See the section [Submit Build File via Network](#) for more information on F4X.



2. Tap the checkbox next to each print job you wish to add to the printer queue. When you have selected all the files you wish to add to the queue, tap Add to Queue.



Note: The printer can store up to 32 queued jobs at a time.

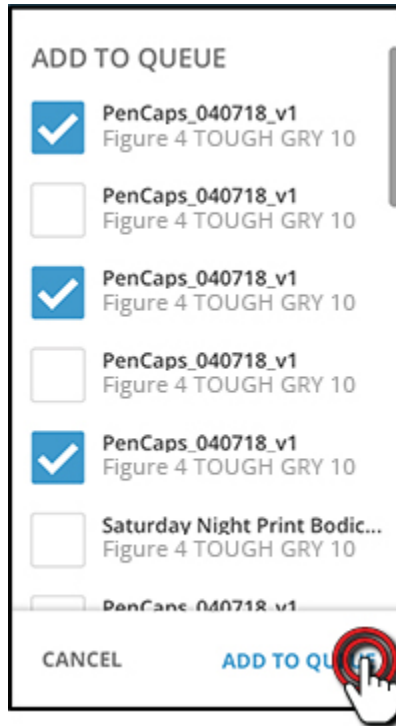

3. You will see a screen like the one at the right to confirm that your jobs have been added to the print queue. Tap Continue to go back to the screen the printer was on before this process.

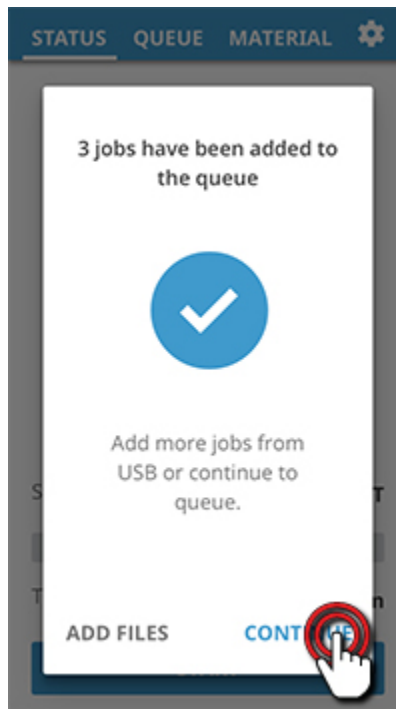

8.4.2 Change Material Before Printing

If the print job sent over from 3D Sprint uses a different print material than that loaded on the printer, one of two screens will pop up, prompting you to take certain actions:

Pending Job Requires a Different Material - Materials Compatible

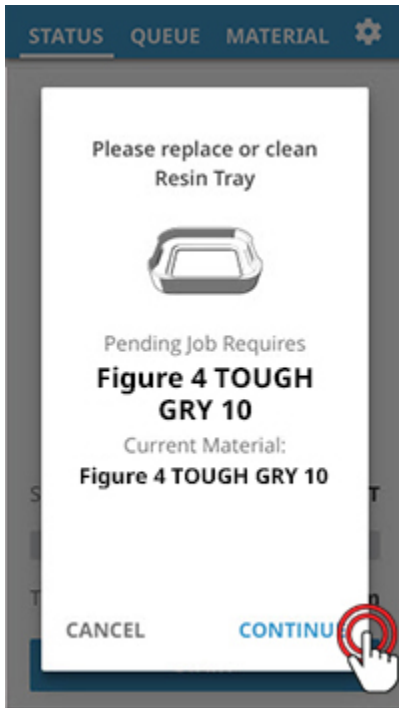

When you see this screen, it means that the material currently loaded on the printer is not the same material that was sent over in the build file AND that the new material and the old material ARE compatible with the same resin tray, according to the section [Resin Tray Material Cross-Usage](#) .You must now:

1. Either replace the resin tray or clean it as seen in the section [Clean Resin Tray](#) . Install the new or cleaned resin tray. Once you have done this, tap Continue.
2. You will see a screen similar to the one below:



3. Scan your material bottle, as in Step 2 of the section [Start Printing](#) . Continue with Step 3 of the printing steps in that section.

Pending Job Requires a Different Material - Materials NOT Compatible

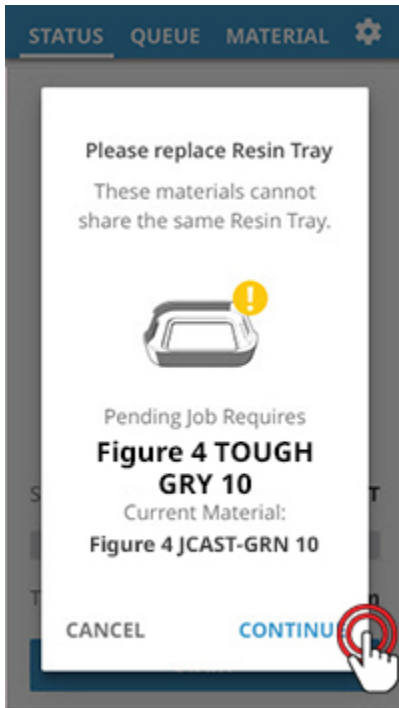

When you see this screen, it means that the material currently loaded on the printer is not the same material that was sent over in the build file AND that the new material and the old material are NOT compatible with the same resin tray, according to the section [Resin Tray Material Cross-Usage](#). You must now:

1. Replace the resin tray. Once you have done this, tap Continue.
2. You will see a screen similar to the one below:



3. Scan your material bottle, as in Step 2 of the section [Start Printing](#). Continue with Step 3 of the printing steps in that section.

8.4.3 QR Code Override

When you scan a bottle's QR code, there could be an error in reading the code itself. You should contact 3D Systems Customer Service to let them know you have a faulty QR code on your bottle. However, it is possible to continue printing for a limited number of builds by overriding the QR code requirement. This section describes how to access QR code override.

1. The first time you experience a scanning error, you will see a screen similar to the one at the right. This can happen if the printer determines it cannot read the code, or if the printer has not read the code within 30 seconds of the scanner being activated.

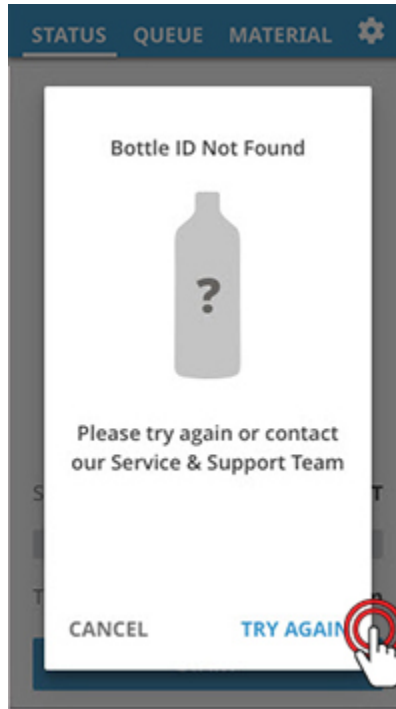

2. The second time you experience a scanning error, you will see a screen like the one at the right. Tap Try Again to scan the bottle again. Tap Select Bottle to go to the QR Code Override screen.



3. If you tapped Select Bottle in Step 2, you will see the screen at the right. This screen shows a list of the last 20 unique bottles scanned to the printer that have not been marked as "empty." Tap the bottle that matches the resin you are using. If you do not see your resin listed, contact 3D Systems Customer Service.

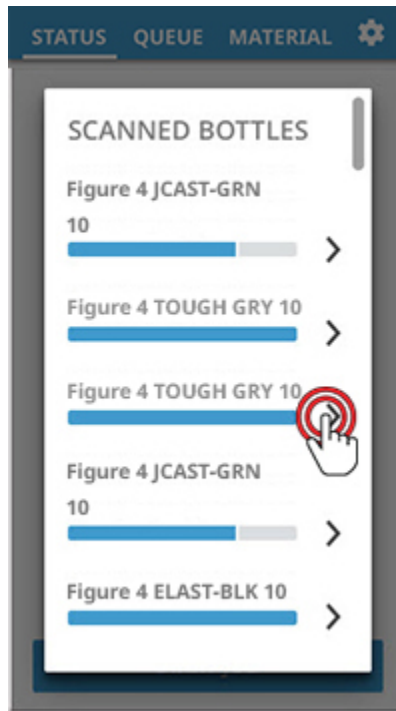

4. Once you have selected a bottle, you will see a confirmation screen like the one at the right. Tap Select to confirm the bottle. The printer will then pick up with Step 4 from the section [Start Printing](#) .

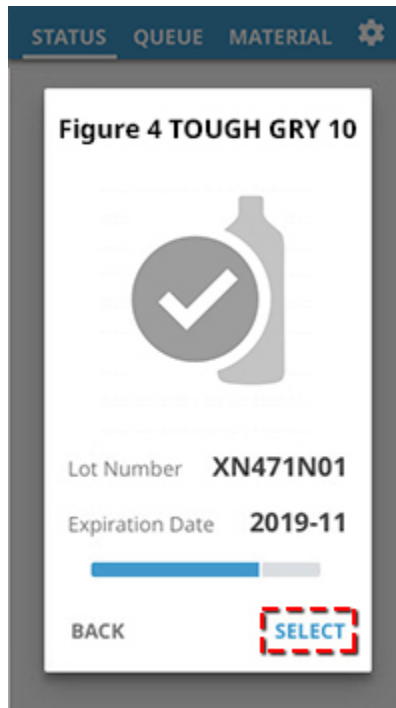

5. If you have exceeded the amount of overrides the system allows, you will see a screen like the one at the right and will not be allowed to override the QR code requirement anymore. Tap Try Again to scan your bottle again or scan a new bottle. Contact 3D Systems Customer Service for more information.

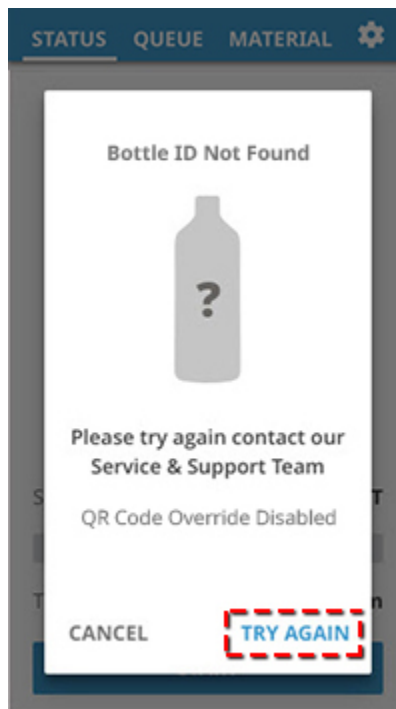

8.4.4 Abort a Print Job

There are two ways that you may abort the print job:

1. Trip a printer sensor during a print.
2. Tap the Abort button on the touch screen:

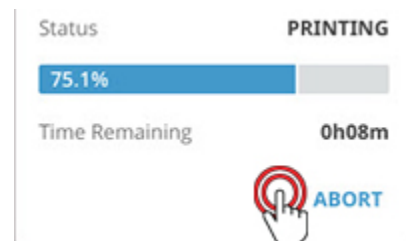

Safety Sensor is Tripped

The printer has three safety sensors that, when tripped, will abort the current print job without warning. In any of these cases, you will see the screen at the right and the elevator will move to the offload position.

1. Lid - Because the resin cures with UV light, exposure of the printed part during printing to any other light besides that of the projector can cause a failed build and can cure the resin in the resin tray. For this reason, if you open the printer lid or lower-chamber door during printing, the print job will be aborted.
2. Front Door - To avoid operator exposure to optical radiation, the printer will also abort the current job if the front door of the printer is opened during printing.
3. Catch Tray - In the unlikely event that the catch-tray sensor malfunctions during a build, or if the catch tray becomes loose during a build, the print job will abort to protect the bottom of the print engine.



CAUTION: Take care not to place the printer in a place where it might be run into or shaken, causing any of the above actions to happen accidentally.

One of the three sensors might also trip just after you press the Start Job button in Step 5 of the section [Start Printing](#) . This will abort the pending job and you will see the screen below:

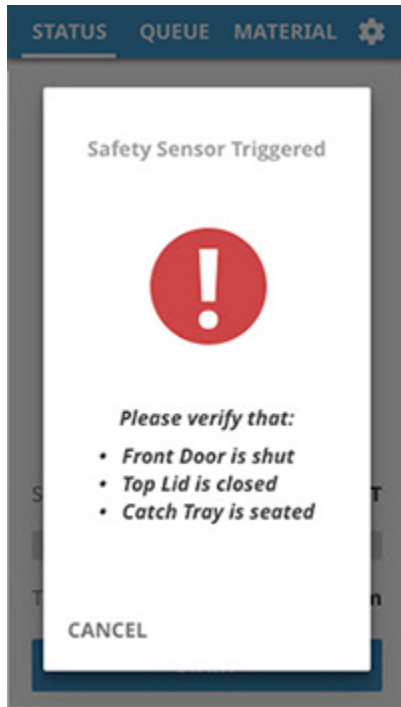
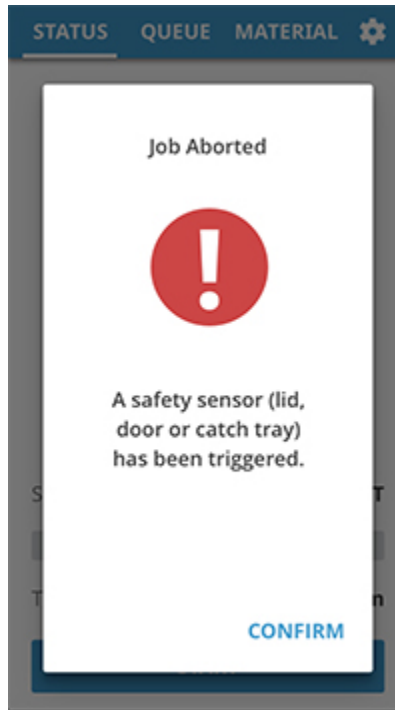

Tap "Abort" Button

1. Tapping the Abort button during a print will not immediately abort the print. You will see the popup at the right. Tapping the Abort button on this screen will abort the job. There is no further warning.

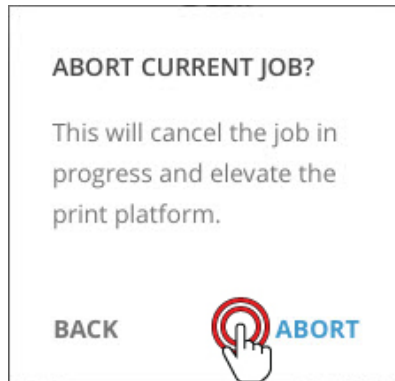

2. You will see the screen at the right and the elevator will stop moving.



3. Once the build is aborted in either case, the printer's Status screen will appear like the one at the right. You can take the following actions:

- a. Tap the Reprint button to restart the build. This will begin the printing process again from Step 1 in the section [Start Printing](#).
- b. Tap the Next Job button to prepare the printer for accepting a new build.

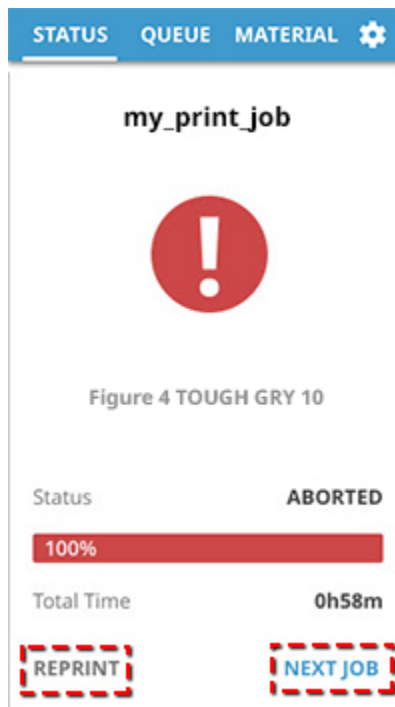

8.4.5 Submit Build File via Network

One way to submit your build file to the printer is over your network via 3D Sprint. This section summarizes the process. For full 3D Sprint instructions, see the [3D Sprint Help Menu](#).

1. In 3D Sprint, click Add to Queue. This will automatically send the build file as a .f4x file.

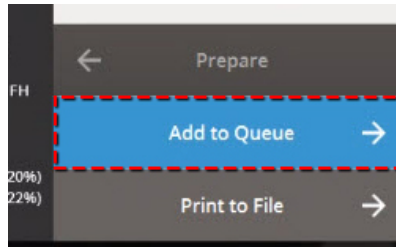

2. The print job will appear as pending in the queue for up to five minutes before being able to print.



Note: The F4X file format will slice the file on the printer itself, as opposed to the PXL file format, which slices the file in 3D Sprint before outputting it. See the section [Submit Build File via USB](#) for more information on the PXL format.

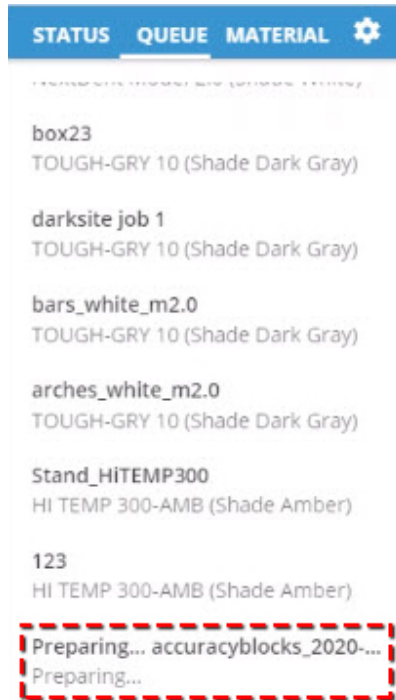

8.5 Figure 4 Standalone Change Air Filter

Frequency: Every 3 months, or when prompted by touch screen

The printer software will alert you periodically to replace the air filter, located on the back of the lower build chamber. A fan inside the printer pulls air in to cool off the printer components. This filter keeps contaminants out of the air being pulled in. If the filter gets resin on it, it must be replaced IMMEDIATELY.



CAUTION: If you need to move the printer to perform this procedure, you must remove the resin tray and place it in its garage before beginning. Also, you will need to lift all leveling feet to move the printer and will need to re-level the printer once this procedure is done.



CAUTION: Failure to change the filter when prompted could lead to a clogged filter, which would block the cooling fan from taking in air. This could cause printer parts to overheat and fail. Similarly, installing a damaged or used air filter may result in overheating or debris getting in the lower print chamber.

1. Remove the two hand screws securing the bracket to the printer.



2. Pull the filter out by the cardboard. Discard the filter with your normal trash.



3. Inspect the new filter to ensure that it is not damaged in anyway or dirty. Install your new air filter with the convex part facing out.

4. Replace the air-filter bracket and secure with screws taken out in Step 1. Be certain that the screw is tightened adequately and that the bracket fits snugly on the printer frame. Also be sure that the arrow indicating air-flow direction on the filter is pointing toward the printer.



8.6 Figure 4 Standalone Change Carbon Filter

Frequency: Every 6 months, or when prompted by touch screen

The printer software will alert you periodically to replace the carbon filter, located on the back of the upper build chamber. If the filter gets resin on it, it must be replaced IMMEDIATELY.



CAUTION: If you need to move the printer to perform this procedure, you must remove the resin tray and place it in its garage before beginning. Also, you will need to lift all leveling feet to move the printer and will need to re-level the printer once this procedure is done.



CAUTION: Failure to change the filter when prompted could lead to a clogged filter, which would trap noxious fumes in the print chamber. Upon opening the printer, these fumes could be very potent. Failure to change the filter could also result in a loss of positive pressure in the print chamber, causing it to lose its "clean-room-like" properties. Do not run the printer without a carbon filter installed.

1. Remove four thumb screws by hand from the carbon-filter bracket. The bracket may be removed if you wish.



2. Remove the filter and discard it according to all local, state, and federal regulations.



Wear Protective Gloves: WEAR 100% NITRILE GLOVES WHEN HANDLING A CONTAMINATED FILTER.



3. Inspect the new carbon filter to ensure that it is not damaged in any way or dirty. Install the filter inside the empty bracket.



4. Secure the carbon-filter bracket in place with the four thumb screws.



8.7 Figure 4 Standalone When Printer is Idle - Sleep Mode

When the printer is idle, be mindful of the following:

1. Be sure to keep the printer lid closed to keep out dust and other debris, as well as to keep any fumes inside the printer.
2. After a time, the printer will go into Sleep Mode: the touch screen will turn off, while the printer will remain turned on. You can wake up the screen by touching it.



Note: The screen the printer fell asleep on will still be present, and will still register a button press if a button is active on the screen. It is recommended to touch the screen at the top when waking it up, since the buttons at the top are simply menu buttons, and accidental presses will not perform critical actions.

8.8 Figure 4 Standalone Running a Resin Tray Cleaning

Any time you experience a failed build, there will more than likely be partially cured resin either floating in the resin tray or stuck to the resin-tray film. Because of this, you must perform a Resin Tray Cleaning after a failed build, even if floating debris in the tray is not obvious. The following steps describe the process.

1. Remove the print platform from the machine. This print does not need to adhere to the print platform and might be difficult to remove from the platform.



2. On the printer, tap the  button to open the Settings screen. Tap the Resin Tray Cleaning Tool icon.

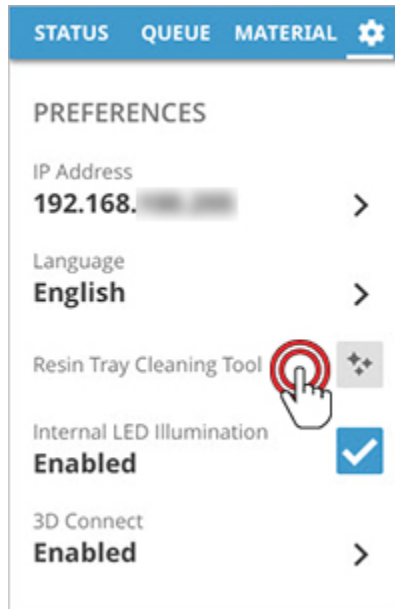

3. You will see the screen at the right. Tap the Clean Tray button.

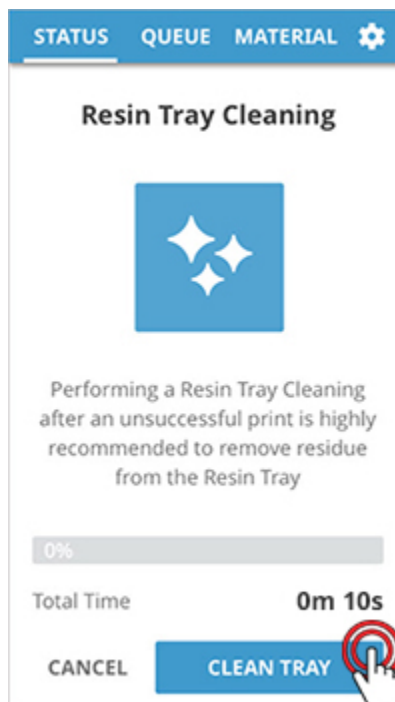

4. If you have not done so, remove the print platform. Ensure printer lid and front door are closed and tap Start.



5. The cleaning print will now begin. This build cannot be aborted, even if you open the lid and front door. It must complete once it is started. You will note there is a progress bar on the screen and a Remaining Time indicator. Once the build is finished, the printer screen will change. Tap Next Job to prepare the printer for the next build.

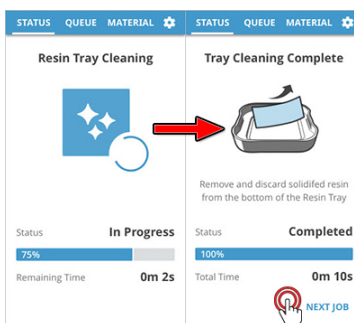

6. Wait at least one minute after job completion. Use the Resin Mixer to get under the printed sheet and remove it from the tray. **Clean** and **cure** the printed sheet so that you can discard it with regular trash.

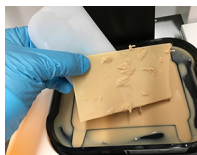

8.9 Figure 4 Standalone Special Considerations for Rigid 140C Black Material



CAUTION: Ensure that any material in the tray is removed by the end of the day, and that the tray is cleaned, as this material WILL solidify within 24 hours.

Figure 4® Rigid 140C Black requires special mixing instructions to help ensure that your parts possess the expected mechanical properties.

Mixing Instructions



Select an appropriately-sized polypropylene bottle/container for material mixing. Other types of containers may be used, as long as the container is non-reactive. The same mixing bottle may be used for every Rigid 140C Black build, as long as:

1. The bottle is used every day to mix material

OR

2. If the bottle will not be used for an extended time, it should be thoroughly cleaned with >90% alcohol before it is stored.



Mix Ratio



Fill mixing bottle with 95 parts of part A material.



Fill mixing bottle with 95 parts of part A material.

Close your mixing bottle and shake up and down vigorously for two minutes.

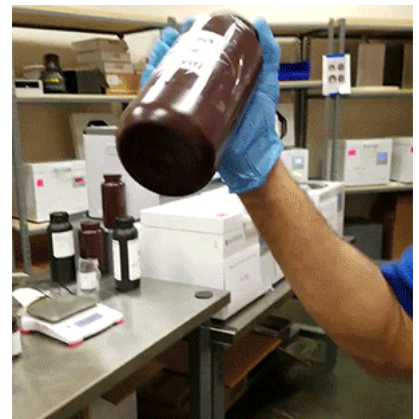

Resin Tray Loading Instructions



Post Processing

Solvent saturation

- TPM should be replaced when cloudy. To extend the life of the solvent, you can filter some resin with cheesecloth or other fine filter media. Discard waste resin according to local government regulations.
- IPA should be replaced when cloudy, or when green parts remain sticky after second rinse. Decant the top of the IPA into a fresh container and discard the residue at the bottom of the container according to local government regulations.

Cleaning parts manually Ultrasonication is not recommended for cleaning parts printed with this material. Instead, clean the parts as in the section [Clean Parts Manually](#), but using the following specific instructions.

1. Fill your dirty container with TPM
2. Shake the covered TPM container with your parts for five minutes.
3. Flush parts with IPA for one to two minutes, ensuring that all TPM residue is gone. Make sure to remove resin from holes, corners of parts, and other areas where the uncured resin might not fall away easily. You may need to use swabs, small tools, and low-pressure compressed air to remove resin from tight areas of parts. Use a soft brush to remove any areas of white precipitation caused by the reaction of IPA with the uncured resin.
4. Dry your parts and remove supports as seen in the section [Dry the Build Parts](#). For this material specifically, dry for 25 minutes at 35°C (95°F). Your parts must be completely dry before being post cured.

UV Post Curing For this material, both UV and thermal post curing are required to achieve full curing and desired mechanical properties.

1. Place the part in the LC-3DPrint Box for 90 minutes.

TIP: Hanging the part in the center of the cure unit provides the best results. TIP: For flat parts that may have a tendency to curl, raise glass plate a quarter to halfway up in the curing unit for a more even cure. You can do this by using glass jars to prop up the glass plate.

2. After curing, let parts cool down until they reach ambient temperature to avoid dimensional inconsistencies.

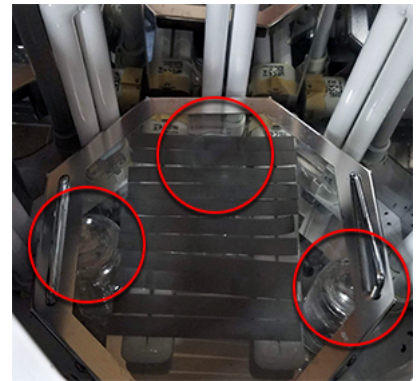

Thermal Post Curing Steps



9 FIGURE 4 STANDALONE POST PROCESSING

Introduction

Once your 3D build has completed, the part on the platform is considered green until it has been through post-processing. A green part must be handled with nitrile gloves at all times. This section describes how to post-process the part, rendering it safe to handle without nitrile gloves. You will need lint-free paper towels (or absorbent cloth) to catch resin that may drip from the part, as well as two stainless-steel or glass containers in which to submerge the part in your solvent of choice.

Note: Always wear 100% nitrile gloves during post-processing procedures.



CAUTION: Always follow the precautions noted in the SDS (Safety Data Sheets) for any resin or solvent being used. It is important to limit the exposure of the resin tray to light, as too much exposure will begin to solidify the resin inside it and render it unsuitable for part building. Place resin-tray cover over resin tray when not in use, close the printer door, or empty the material from the resin tray back into a material bottle of the same resin, sealing the bottle.

Remove Print Platform

1. Allow the printed part to drain over the resin tray until resin stops dripping off the part. Once this is done, open the printer lid. You will see the screen below on the printer:

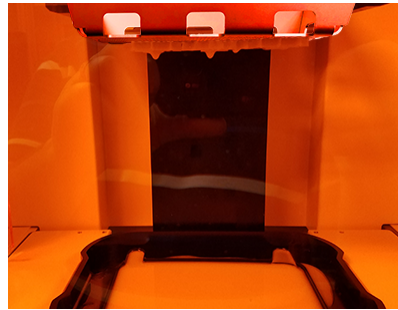

Lid Open

Please remove the print platform and install a clean platform to continue

Status **Completed**
100%
Total Time **1h 12m**

2. Wearing nitrile gloves, tilt the print platform over the resin tray such that any remaining resin is drained into the resin tray.



3. Place a paper towel or gloved hand under the part and lift the print platform out of the machine. The paper towel will keep resin from dripping on unwanted surfaces.



CAUTION: Do not remove the printed part from the print platform while both are still in the machine. Doing so risks getting partially cured print material in the resin tray, which will cause future builds to fail and/or cause the resin-tray membrane to puncture.



4. If you have another print job in your 3D Sprint queue, or if you want to reprint the same job, you may now insert a clean print platform, as the screen in Step 1 suggests. Closing the printer lid at this time will show the screen at the right, whether you insert a new platform or not. You may now:

- a. Reprint the previous job
- b. Print the next job in your 3D Sprint queue. If there is no pending job in your 3D Sprint queue, you will not see the Next Job button.

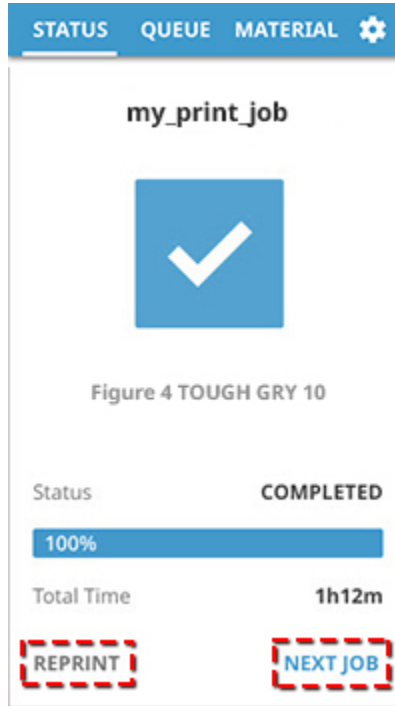

9.1 Figure 4 Standalone Remove Printed Parts From Platform

You must now remove the printed part(s) from the print platform to prepare them for cleaning.



Wear Protective Gloves: WEAR 100% nitrile gloves whenever handling uncured or partially cured print material.



CAUTION: Ensure that any tools you use in post-processing have been cleaned since their last use.

1. Put a nonabrasive cloth/lint-free paper towel underneath the print platform. Using the included punch tool, remove printed part from the print platform by pushing on it through the top side of the platform. Hold it the way you would a rubber stamp.



2. Once the parts are off the platform, rinse them in IPA by hand, holding them over a container that can catch the solvent.



Special Considerations for Elastomeric Resins

If you are running elastomeric resins, such as ELAST-BLK 10, it may be difficult to remove parts from the print platform using only the punch tool. If this is the case, perform the following steps:

3. Use the punch tool as described in Step 1 above. This will get the part started in detaching from the platform.
4. Use the Platform Scraper to fully remove the part from the platform.

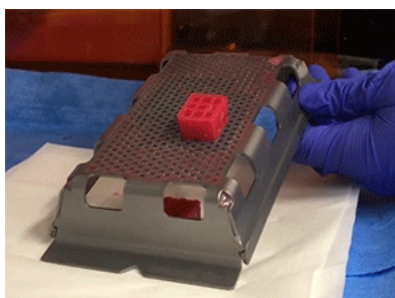

5. For instructions on removing the remaining, partially cured resin, see the section [Clean Print Platform](#) .

9.2 Figure 4 Standalone Cleaning Printed Parts

Printed parts must be cleaned with solvents to ensure safer handling, dimensional accuracy, and preparation for post-curing. This section will describe three methods that have been proven to work best for Figure 4 part cleaning: 1. Sonication in IPA; 2. Non-flammable Sonication; and, 3. Manual Cleaning.

Necessary Cleaning Materials Chart

EQUIPMENT	SONICATION IN IPA	NON-FLAMMABLE SONICATION	MANUAL CLEANING
At least 1 ultrasonic unit for wash - this unit should be large enough to hold your cleaning containers (see below)	yes, explosion-proof unit required	yes	no
At least 2 containers for part baths - these should be large enough to contain the parts you intend to print. These containers can be stainless steel or glass. Plastic is not recommended for ultrasonication.	yes	yes	yes
Supply of solvent(s)	yes	yes	yes
Digital Timer	yes	yes	yes
Vented wash/squirt bottle for IPA	yes	yes	yes
Jar to store cleaning brushes	yes	yes	yes

EQUIPMENT	SONICATION IN IPA	NON-FLAMMABLE SONICATION	MANUAL CLEANING
Soft or medium bristle brushes - 1 brush included with printer	yes	yes	yes
Compressed air with air blow gun with chip guard	yes	yes	yes
Hydrometer with range or 0.70-0.81 for IPA	yes	no	yes
Hydrometer with range or 0.795-0.910 for EZ Rinse C	yes	no	no
Hydrometer with range or 1.00-1.22 for propylene carbonate	no	yes	no
500ml graduated cylinder	yes	yes	yes
Optical inspection tool, such as a microscope	yes	yes	yes
Forced-air oven (optional for part drying)	yes	yes	yes



WARNING: IPA IS A FLAMMABLE LIQUID WITH FLAMMABLE VAPORS. KEEP AWAY FROM HEAT, SPARK AND OPEN FLAMES. USE WITH ADEQUATE VENTILATION. STORE AT 20-30°C (68-86°F). DO NOT TAKE INTERNALLY. AVOID PROLONGED OR REPEATED BREATHING OF MIST OR VAPOR. LIQUID AND VAPOR CAUSE IRRITATION TO EYES AND RESPIRATORY TRACT. LIQUID AND VAPOR AFFECT CENTRAL NERVOUS SYSTEM. MAY BE HARMFUL IF ABSORBED THROUGH SKIN. MAY CAUSE IRRITATION TO SKIN.



CAUTION: Consult SDS for each solvent and material type prior to use for additional personal protective equipment.



CAUTION: solvents and solvent-related trash must be disposed of according to all government regulations.



Wear Protective Gloves: Always wear gloves when cleaning build parts.

9.2.1 Cleaning Chart



Note: If you wish to print this page, scroll to the bottom of this page and click the "printer friendly version" link. On the page in the new tab, press ctrl+P (cmd+P on Mac) to print the document or save it as a PDF. Print/save in landscape orientation and 50% scale for best results to print the full chart.

Depending on your requirements, choose which of the following three methods best suits your printing applications:

1. Sonication in IPA - Recommended as a starting point for high-volume, robust cleaning systems. This uses 3D Systems' EZ Rinse C cleaning solvent and IPA or Propylene Carbonate from your local supplier. Due to the flammability of IPA, you must use an explosion-proof ultrasonic cleaner.
2. Non-flammable Sonication - Recommended for ultrasonic users who cannot use IPA. This method is not as effective as method #1 above. Raising the bath temperature of the rinse solution and regularly changing the bath are ways to improve cleaning efficiency.
3. Manual Cleaning - Recommended for those without access to ultrasonic equipment, but can use IPA. This method requires extra steps during washing and rinsing: 1. The part must be brushed with the included brush; and, 2. The part must be sprayed with compressed air. The operator must be careful handling parts which are still delicate at this stage.

Please use the chart below for the recommended cleaning times for each method.

Recommended solvents for material spills - For any of the solvents listed below as being used for a "Wash" cycle, you may also use that solvent to clean material spills.

Three Options For Cleaning

Choose ONE of the three options below for part-cleaning based on your needs. See further description of these methods listed above.

If you do not see your material, SCROLL or SWIPE DOWN on the chart below.

MATERIAL TYPE	1. SONICATION IN IPA		2. NON-FLAMMABLE SONICATION		3. MANUAL CLEANING	
	WASH	RINSE	WASH	RINSE	WASH	RINSE
Figure 4 Tough Clear	Propylene Carbonate do not exceed 2.5 min.	IPA do not exceed 2.5 min.	NOT RECOMMENDED	NOT RECOMMENDED	Dirty IPA do not exceed 2.5 min.	Clean IPA do not exceed 2.5 min.
Figure 4 TOUGH GRY 10 Figure 4 TOUGH GRY 15 Figure 4 ELAST-BLK 10	EZ Rinse C do not exceed 5 min.	IPA do not exceed 5 min.	Propylene Carbonate do not exceed 5 min.	5 wt% Elma Tec A4 Solution do not exceed 5 min.	Dirty IPA do not exceed 2.5 min.	Clean IPA do not exceed 2.5 min.
Figure 4 JCAST-GRN 10	n/a	IPA do not exceed 3 min.	Propylene Carbonate do not exceed 5 min.	5 wt% Elma Tec A4 Solution do not exceed 5 min.	n/a	Clean IPA do not exceed 3 min.
Figure 4 FLEX-BLK 10 Figure 4 TOUGH-BLK 20 Figure 4 FLEX-BLK 20 Figure 4 EGGSHELL-AMB 10 Figure 4 RUBBER-65A BLK	EZ Rinse C do not exceed 5 min.	IPA do not exceed 5 min.	EZ Rinse C do not exceed 5 min.	5 wt% Elma Tec A4 Solution do not exceed 5 min.	Dirty IPA do not exceed 2.5 min.	Clean IPA do not exceed 2.5 min.
Figure 4 MED-AMB 10 Figure 4 MED-WHT 10	Dirty IPA do not exceed 3 min.	Clean IPA do not exceed 2 min.	n/a	n/a	Dirty IPA do not exceed 2.5 min.	Clean IPA do not exceed 2.5 min.
Figure 4 HI TEMP 300-AMB	DO NOT SONICATE	DO NOT SONICATE	DO NOT SONICATE	DO NOT SONICATE	Dirty IPA do not exceed 2.5 min.	Clean IPA do not exceed 2.5 min.
Figure 4 PRO-BLK 10 Figure 4 Rigid White	EZ Rinse C do not exceed 5 min. Use lowest sonication setting	IPA do not exceed 5 min. Use lowest sonication setting	NOT RECOMMENDED	NOT RECOMMENDED	Dirty IPA do not exceed 2.5 min.	Clean IPA do not exceed 2.5 min.

MATERIAL TYPE	1. SONICATION IN IPA		2. NON-FLAMMABLE SONICATION		3. MANUAL CLEANING	
	WASH	RINSE	WASH	RINSE	WASH	RINSE
Figure 4 RUBBER-BLK 10 Note: Some material components do not dissolve in IPA. Do not use IPA for first bath.	Propylene Carbonate do not exceed 2.5 min.	IPA do not exceed 2.5 min.	Propylene Carbonate do not exceed 5 min.	5 wt% Elma Tec A4 Solution do not exceed 5 min.	Propylene Carbonate do not exceed 5 min.	Clean IPA do not exceed 5 min.
Figure 4 JEWEL MASTER GRAY	Dirty IPA do not exceed 5 min.	Dirty IPA do not exceed 5 min.	NOT RECOMMENDED	NOT RECOMMENDED	Dirty IPA do not exceed 5 min.	Dirty IPA do not exceed 5 min.
Figure 4 RIGID GRAY	Dirty IPA do not exceed 5 min.	Clean IPA do not exceed 5 min.	Propylene Carbonate do not exceed 5 min.	5 wt% Elma Tec A4 Solution do not exceed 5 min.	Dirty IPA do not exceed 2.5 min.	Clean IPA do not exceed 2.5 min.
Figure 4 TOUGH 60C WHITE	Dirty IPA do not exceed 5 min.	Clean IPA do not exceed 5 min.	Propylene Carbonate do not exceed 5 min.	5 wt% Elma Tec A4 Solution do not exceed 5 min.	Dirty IPA do not exceed 2.5 min.	Clean IPA do not exceed 2.5 min.
Figure 4 TOUGH 65C BLACK	EZ Rinse C do not exceed 5 min.	Clean IPA do not exceed 5 min.	Propylene Carbonate do not exceed 5 min.	5 wt% Elma Tec A4 Solution do not exceed 5 min.	EZ Rinse C do not exceed 5 min.	Clean IPA do not exceed 5 min.
Figure 4 High Temp 150C FR Black	DO NOT SONICATE	DO NOT SONICATE	DO NOT SONICATE	DO NOT SONICATE	Dirty IPA do not exceed 2.5 min.	Clean IPA do not exceed 2.5 min.
Figure 4 Rigid 140C Black	See this page	See this page	See this page	See this page	See this page	See this page

*For all materials, minimize ultrasonic power setting to less than 100W

Overview of Recommended Solvents

SOLVENT	CHEMICAL ABSTRACTS SERVICE #	SPECIFIC GRAVITY @ 25°C (G/ML)	FLASH POINT	BOILING POINT	RECOMMENDED FORM
IPA	67-63-0	0.785	12°C (53.6°F)	83°C	use neat
EZ Rinse C	67784-80-9, 68919-53-9	0.88	> 218°C (> 424.4°F)	> 301°C (573.8°F)	use neat
Propylene Carbonate	108-32-7	1.20	116°C (240.8°F)	240°C (464°F)	use neat
Elma Tec Clean A4	Mix	1.13	> 100°C (> 212°F)	not applicable	mix 5 wt% in water

When to Change Cleaning Solvents

You may change out the cleaning solvent in your containers whenever you feel that the solvent is not doing a good enough job stripping printed parts of uncured resin. However, you may also choose to have a hydrometer on-hand to measure the specific gravity of your solvent/resin mixture. The table below shows what measurements will prompt which actions you can take.

SOLVENT	SPECIFIC GRAVITY VALUES
IPA - Hydrometer range 0.700 - 0.810	Clean: do not change solvent if < 0.787 Dirty: use the solvent for "dirty" baths if between 0.787 - 0.797 Discard: Discard solvent according to all government regulations if > 0.797
EZ Rinse C - Hydrometer range 0.795 - 0.910	Clean: do not change solvent if < 0.886 Dirty: use the solvent for "dirty" baths if between 0.886 - 0.903 Discard: Discard solvent according to all government regulations if > 0.903
Propylene Carbonate - Hydrometer range 1.000 - 1.220	Clean: do not change solvent if > 1.197 Dirty: use the solvent for "dirty" baths if between 1.197 > x > 1.190 Discard: Discard solvent according to all government regulations if < 1.190



Note: Use IPA ≥ 90% purity.



Tip: Using compressed air to clear small holes and features of EZ Rinse C prior to IPA cleaning improves ease of cleaning. Use soft brush to aid in cleaning if a ultrasonic cleaner is not available. The clean IPA that becomes saturated in the Rinse container should then be used for the Wash container until it is no longer effective at removing resin. After your Wash container's solvent becomes saturated, discard it according to all government regulations. Please see the table above for how often to change your solvent mixture.



WARNING: IPA IS FLAMMABLE AS BOTH LIQUID AND VAPOR. KEEP AWAY FROM HEAT, SPARK AND OPEN FLAMES. USE WITH ADEQUATE VENTILATION. STORE AT 20-30°C (68-86°F).



WARNING: THE FEDERAL OSHA REQUIREMENT 29 CFR PART 1910.242(B) STATES: COMPRESSED AIR SHALL NOT BE USED FOR CLEANING PURPOSES EXCEPT WHERE REDUCED TO LESS THAN 30 PSI AND THEN ONLY WITH EFFECTIVE CHIP GUARDING AND PERSONAL PROTECTIVE EQUIPMENT. FOR ADDITIONAL INFORMATION, GO TO [HTTPS://WWW.OSHA.GOV/PLS/OSHAWEB/OWADISP.SHOW_DOCUMENT?P_TABLE=STANDARDS&P_ID=9849](https://www.osha.gov/pls/oshaweb/owadisp.show_document?p_table=standards&p_id=9849).

9.2.2 Cleaning Parts Using an Ultrasonic Cleaner



Note: Follow all safety precautions and guidelines set forth in the User Guide for the ultrasonic cleaner you have purchased.

Note: Always wear 100% nitrile gloves whenever handling an uncured printed part, as well as when handling any solvent used to clean such parts.



CAUTION: The federal OSHA requirement 29 CFR Part 1910.242(b) states: Compressed air shall not be used for cleaning purposes except where reduced to less than 30 psi and then only with effective chip guarding and personal protective equipment.

While the User Guide for your ultrasonic cleaner will provide specific-use instructions, the steps outlined below describe how 3D Systems recommends cleaning build parts via an ultrasonic cleaner. This procedure will reference the [Cleaning Chart](#) from the previous section. There are two ways to set up you ultrasonic cleaner:

1. Indirect ultrasonic energy transfer - Energy is transferred through a medium, such as water, before it reaches your solvent containers inside the tanks. If space in your cleaner allows, you may place both Wash and Rinse tanks in the cleaner at the same time. Use this setup if you only have one ultrasonic cleaner available.
2. Direct ultrasonic energy transfer - Your Wash and Rinse solvents are the medium for energy transfer. In this case, each solvent is poured directly into its own, dedicated ultrasonic cleaner. Use this setup if you have at least two ultrasonic cleaners available.

Cleaning Procedure

1. Label your steel or glass containers as Wash and Rinse.
2. Wearing nitrile gloves, place the printed part inside your Wash container. Pour Wash solvent into the container until you completely submerge the printed part. Ensure the solvent is not saturated for this step. Please see the section [When to Change Cleaning Solvents](#) for more information.
3. Place Wash container inside the ultrasonic cleaner.



CAUTION: Ensure that your ultrasonic cleaner is properly rated to use flammable solvents. Failure to do so could present a fire hazard.



4. Follow the instructions in your ultrasonic cleaner's User Guide to power it on and begin cleaning. Run the Wash cycle for the time specified in the [Cleaning Chart](#).
5. After the Wash cycle has finished, remove the printed part from the ultrasonic cleaner using nitrile gloves. You may wish to use shop air or an air compressor to dry the part in between cleanings, as this is an effective method for getting one solvent off the part before cleaning it with another.
6. For the Rinse cycle, follow Steps 2-5 once more, using the Rinse solvent specified in the [Cleaning Chart](#). You may wish to use shop air or an air compressor to dry the part after this Rinse cycle.
7. Inspect the part for shiny areas and surface tackiness. If either exists, there could still be uncured resin on the part. Use your solvent squirt bottle and cleaning brush to further clean the part. Dry the part with compressed air. Repeat this process as needed until no shiny or sticky areas remain on the part.
8. Be sure to rinse your cleaning brush(es) in fresh IPA and place covers on your solvent containers when not in use.
9. The printed part is now ready for drying and UV post-curing.



CAUTION: Cleaning printed parts for any longer time than prescribed in this manual risks creating defects in the part.

9.2.3 Cleaning Parts Manually



Note: Some materials require that you use an ultrasonic cleaner, rather than manual cleaning methods, to clean printed parts. Please read the [Cleaning Chart](#) to determine if manual cleaning is sufficient.



CAUTION: The federal OSHA requirement 29 CFR Part 1910.242(b) states: Compressed air shall not be used for cleaning purposes except where reduced to less than 30 psi and then only with effective chip guarding and personal protective equipment

The following instructions are recommendations for hand-cleaning parts made with Figure 4 print materials.

1. Mark containers as Wash and Rinse.
2. Place printed part into Wash container.
3. Add Isopropyl Alcohol (IPA) to Wash container until it completely submerges the printed part(s). Fasten the lid on the container.



Note: You may use "dirty" solvent for this first part bath, as specified in the chart [When to Change Cleaning Solvents](#). Once the "dirty" solvent has reached "discard" status, according to the chart, discard it according to all government regulations.

4. Lightly shake the container back and forth, just enough to agitate the liquid. Follow the instructions in the [Cleaning Chart](#) for how much time is required for the Wash cycle. Use a countdown timer to assist. You may also need to use the included Part-Cleaning Brush while the part is submerged to clean part surfaces and fine features.

5. Remove part(s) from Wash container and allow excess IPA to drip from the part(s) for 30 seconds. You may wish to use shop air or an air compressor to dry the part in between cleanings, as this is an effective method for getting one solvent off the part before dipping it into another.

6. Place printed part(s) into Rinse container.

7. Follow steps 3-5, but this time using clean IPA. Follow the instructions in the [Cleaning Chart](#) for how much time is required for this second bath.



Note: You must use "clean" IPA for the second part bath, as specified in the chart [When to Change Cleaning Solvents](#). Rinsing with dirty solvent in this step risks not completely cleaning the part of uncured liquid material.



Tip: Once your IPA has become "dirty," as specified in the chart [When to Change Cleaning Solvents](#), you may use it for the Wash cycle in Step 2.

8. Inspect the part for shiny areas and surface tackiness. If either exists, there could still be uncured resin on the part. Use your solvent squirt bottle and cleaning brush to further clean the part. Dry the part with compressed air. Repeat this process as needed until no shiny or sticky areas remain on the part.

9. Be sure to rinse your cleaning brush(es) in fresh IPA and place covers on your solvent containers when not in use.

10. The printed part is now ready for drying and UV post-curing.

9.2.4 Specific Gravity Measurement

The section [When to Change Your Solvents](#) lists the ranges of specific gravities at different states of your solvent's cleaning life. This section describes specifically how to measure that specific gravity.

1. Use a cup to pour at least 400mL of the bath liquid in a 500mL graduated cylinder.
2. Use the [When to Change Your Solvents](#) table to determine what range hydrometer you need.
3. Gently lower the hydrometer into the graduated cylinder and wait until it stops bobbing up and down.
4. Record where on the hydrometer's graduated markings it hits the solvent's meniscus.
5. Compare that value to what is in the acceptable range according to the chart in Step 2.



Tip: To reduce variation in measurements, liquids should be around 25°C (77°F).



Tip: Elma Tech A4 has a similar density to that of Figure 4 resin. Because of that, a hydrometer test will not work to test saturation. For this solution, simply use your best judgment on printed prints as to whether they are sufficiently clean. If part surfaces are sticky or shiny, it is a good indication that your solvent is not cleaning them enough.

9.3 Figure 4 Standalone Dry the Build Parts

For information on the different methods for drying printed parts, please see the section [Air-Drying Parts](#). Dry printed parts until you see no more liquid on their surfaces. For any drying method, please use the following guidelines:

1. Always dry printed parts over a tub, lab paper towel, or absorbent cloth. Do NOT dry the part over a sink or tub that drains to normal wastewater.
2. Discard any disposable towels used in the drying process according to all local, state and federal regulations. These towels have been in contact with uncured resin and solvents, and must be treated as such.
3. On a regular basis, have a professional cleaning service wash any absorbent cloths used in the drying process.
4. If you dry the part over a tub, periodically empty/clean it, discarding its contents according to all local, state, and federal regulations. The tub has been in contact with uncured resin and solvents and must be treated as such.
5. If using an air compressor in the same room (as opposed to shop air), wear ear protection when it is in use.
6. Always wear 100% nitrile gloves and safety glasses when handling partially cured printed parts. When drying with a high-pressure method, uncured resin or solvent may splash.
7. If you come into contact with uncured resin during part drying or at any time, wash the affected area with soap and COLD water. Any clothes contaminated with uncured resin or solvent must be dry cleaned promptly.

8. There might be remnants of supporting architecture left on your part(s). You can remove these supports by hand in the majority of cases. If you experience any issues removing supports, please see [Troubleshooting item PCI4](#) .

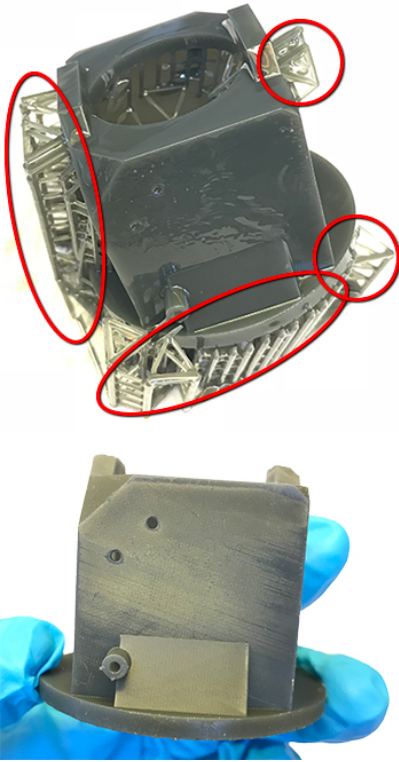

Drying Time Quick Reference

No matter which method you use to dry your part, you must ensure it is completely dry before proceeding to the post-curing step. The chart below serves as a quick reference for suggested air-drying times. If you dry the part with compressed air before letting it out to air dry, you will significantly cut down the time needed for air drying.



CAUTION: Using compressed air is not a replacement for air drying. After drying with compressed air, you must still leave the part out for at least 30 minutes to completely dry.

MATERIAL TYPE	DRYING TIME
All current materials	Ambient or air dry > 1hr. or Oven dry 50°C (122°F), 10 min. For Figure 4 Rigid 140C Black, see Special Considerations for Rigid 140C Black Material .

9.4 Figure 4 Standalone UV Cure the Parts

LC-3DPrint Box

The recommended post-curing oven for the Figure 4 Standalone is the NextDent LC-3DPrint Box. Please see the section [General Post-Curing Requirements](#) for information on the specs an alternate post-curing oven must have

1. After the part is completely dry, insert the part into the middle of the LC-3DPrint Box. If there are multiple parts, ensure there is some space between them on the oven platform. The LC-3DPrint Box has been tested to work with Figure 4 resins. Ideal, tested curing times for this oven are outlined in the [Material Stirring and Curing Chart](#) in the "Operation" section of this manual.



CAUTION: Use nitrile gloves whenever touching or operating the LC-3DPrint Box. Normal usage of the box will most likely get uncured resin on the box handle and buttons; so it is always best to take this precaution. Also, the printed parts are still "green" at this stage, not yet fully polymerized and not safe to touch without gloves.



1. Follow instructions in your UV oven instruction manual to begin the post-curing process. If you have the LC-3DPrint Box, the instruction manual can be found both in the packaging or by downloading the link here: [NextDent LC 3D-Printbox Instructions for Use](#) .
2. Please see the [Material Stirring and Curing Chart](#) in the "Operation" section of this manual for resin curing times. Do not open the curing chamber door until the curing process has been completed. The LC-3DPrint Box has a sensor that will turn the machine off during curing if the lid is open. Please see the User Guide of the resin you are using for full post-curing instructions.



CAUTION: Be careful not to over-cure the part. Over-curing can cause discoloration and part warping.

3. Once the printed part has been fully cured, open the UV oven's lid and let the part cool for about five minutes. Letting the parts cool to room temperature is even more desirable.
4. Remove the part from the UV oven, using nitrile gloves when opening and closing the oven.
5. The printed part is now safe to touch without nitrile gloves.

9.4.1 General Post Curing Requirements

If you choose not to use the LC-3DPrint Box, please ensure the following requirements are met on your UV oven:

- Cure the parts for the same times recommended in the [Material Stirring and Curing Chart](#) .
- Light source should be at least 4 mWatt/cm².
- A broad light spectrum, in the range of 350nm-430nm
- Part-core temperature should reach 60°C-90°C.
- Part can be inspected for color - A yellowish color indicates part is under-cured. Consider the photo below, where the part on the left has not been cured at all, the middle part has been cured for only five minutes, and the part on the right has been fully cured for the recommended 90 minutes for Figure 4 TOUGH GRY 15.



9.5 Figure 4 Standalone Sterilization Protocol for MED-AMB 10 and MED-WHT 10

For Figure 4 MED-AMB 10 and MED-WHT 10 materials, it may be necessary to sterilize cured, finished parts to be used in certain medical applications. You can sterilize printed parts by making use of an autoclave or using gamma-ray sterilization. Do not use

a dishwasher or thermal disinfectant. 3D Systems recommends the following autoclave method as a baseline starting point for sterilization:

1. Ensure printed parts are fully cleaned and cured before sterilizing them.
2. Place your part in a standard sterilization pouch.
3. Apply sterilization by placing the pouch containing the part in an autoclave for 15 minutes at 121°C or 3 minutes at 138°C. Make sure no mechanical forces are applied to the part during sterilization.
4. Let the part cool down to room temperature before using it. Make sure no mechanical forces are applied to the part during cool-down.



Note: The above protocol is a recommended starting point and may not be appropriate for all cases. Different geometries and use may require adjustment of this protocol to maximize effectiveness.

If using an autoclave for sterilization, you will notice that your part will change color with the sterilization process. This is normal. Please see the before/after images below for reference.

MED-AMB 10

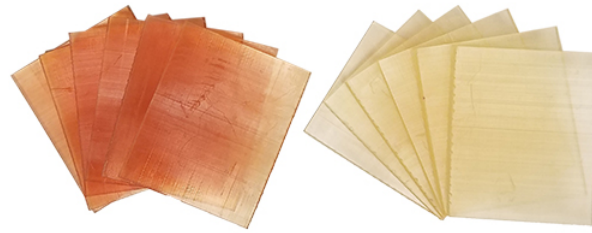

Before sterilization

After sterilization

MED-WHT 10



Before sterilization

After sterilization



Note: Autoclave sterilization may impact the [mechanical properties](#). Small drops in tensile strength, elongation at break, and impact strength may occur. Such changes are typically less than 20%. Use cases that are sensitive to that should be validated.

9.6 Figure 4 Standalone Considerations for Heating Figure 4 HI TEMP 300-AMB

Figure 4 HI TEMP 300-AMB creates printed parts that can withstand high temperatures. However, exposure to different temperatures will change the material's color. A sample set of color changes is seen below:

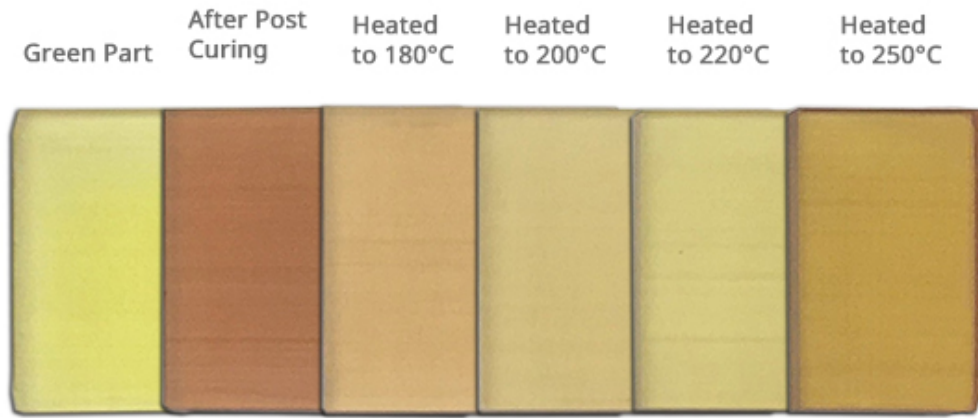

9.7 Figure 4 Standalone Clean Print Platform



CAUTION: Do not clean the print platform or resin tray in a sink or tub that drains into waste-water. These components must be cleaned in a self-contained tub and the solvent/resin mix must be discarded according to all local, state, and federal regulations.



Wear Protective Gloves: ALWAYS WEAR 100% nitrile gloves throughout this procedure.

Clean Print Platform

You must clean the print platform after each use.

1. Use the punch tool to punch out the bits of supporting architecture that are inside the holes. Punch in a column, going up and down until you have run the punch tool through every hole. See the punching pattern below for reference.

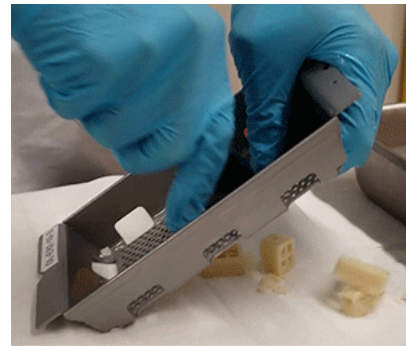
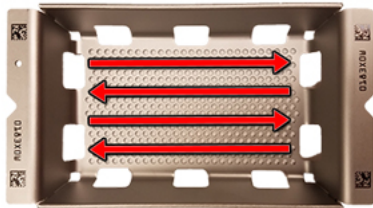

2. Use the Platform Scraper to scrape cured resin off the underside of the print platform. If you are running an elastomeric material such as ELAST-BLK 10, please see the section below, [Special Consideration for Elastomeric Resins](#).

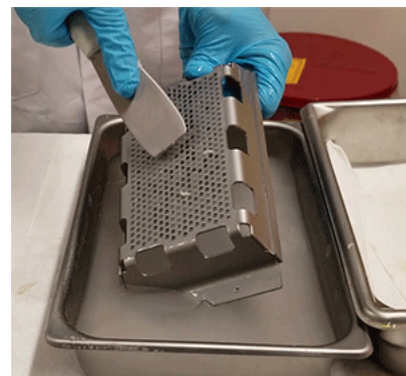

3. You should have the platform-cleaning fixture in a tub with IPA. Place the print platform on the fixture, being sure it is submerged in the solvent, and use the punch tool up and down on the platform once more, as you did in Step 1.



Platform-cleaning fixture

4. Wipe down the platform with a lint-free paper towel or nonabrasive cloth.



5. Inspect the platform, particularly the holes on the flat surface, to ensure no partially cured resin remains. If you find resin or partially cured bits on the platform at this point, follow the steps in this section again on the problem areas.

Your print platform is now clean and ready to be reused.

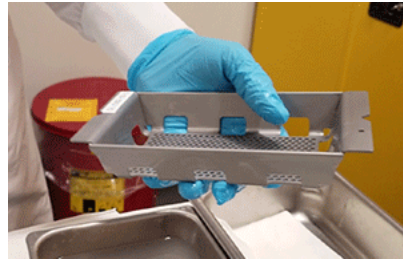

Special Consideration for Elastomeric Resins

For cleaning print platforms that run elastomeric resins such as ELAST-BLK 10, your printer package includes a Wire Brush accessory. The following instructions demonstrate how to use this brush.

1. Use the Platform Scraper to remove as much partially cured resin as you can.

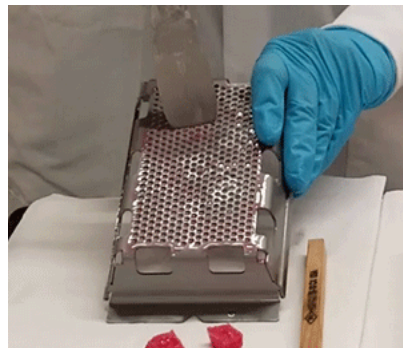

2. Identify all areas of the platform with partially cured resin and use the Wire Brush to scrape off as much as possible.

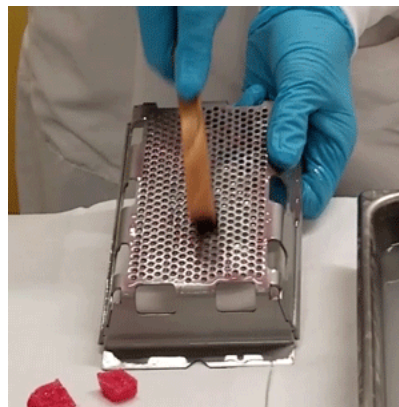

3. Turn the print platform over and use the Wire Brush to scrape all areas that have partially cured resin.

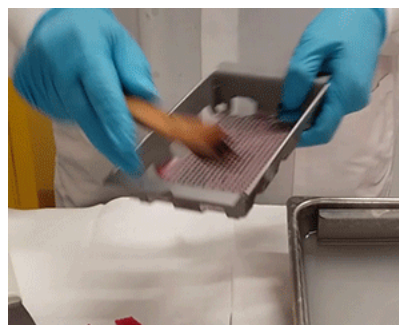

4. Place the print platform in solvent and use the Part-Cleaning Brush to clear away areas of liquid resin.

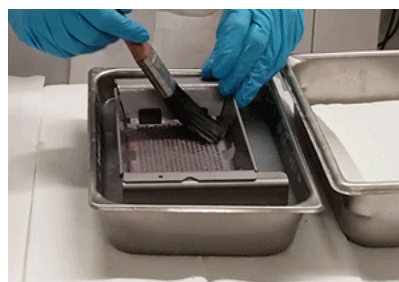

5. Use the Punch Tool if desired to punch bigger chunks of material through the platform. Use the Wire Brush to scrape the remaining partially cured resin from the platform.

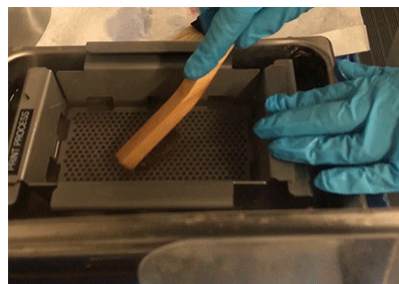

6. Wipe down the platform with a lint-free paper towel or nonabrasive cloth.



7. Inspect the platform, particularly the holes on the flat surface, to ensure no partially cured resin remains. If you find resin or partially cured bits on the platform at this point, follow the steps in this section again on the problem areas.

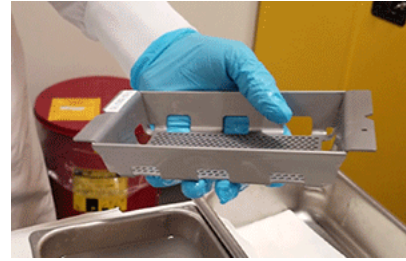

9.8 Figure 4 Standalone Clean Resin Tray

You must clean the resin tray if:

- You believe the resin tray has foreign debris or partially cured print material in it.
- You are using a different print material in the same resin tray.

Every time you remove the resin tray for any reason, you should also inspect/clean the catch tray, as in the section [Clean/Replace the Catch Tray](#).



Note: The elevator must be at its upper limit and the print platform must not be in the printer during this procedure.



Note: Two iterations of this process tends to be enough for a fully cleaned resin tray. If you find that you need to repeat this process more than once, consider spending more time brushing the membrane/tray when soaked in >90% alcohol solvent.



Note: Avoid touching the bottom of the membrane during this procedure. If resin is observed on this surface, spot clean with >90% alcohol solvent by squirting/pouring solvent on the area with uncured resin. Finish by drying with compressed air. Do not touch Part-Cleaning Brush or any other tool to the bottom of the membrane.

Procedure

1. Push in the tension-arm release lever and lift tension arm.
2. Using nitrile gloves and using both hands, slowly lift the resin tray out of the printer.



CAUTION: Take care not to hit the resin tray on the elevator arms, printer lid, or other printer components during removal.

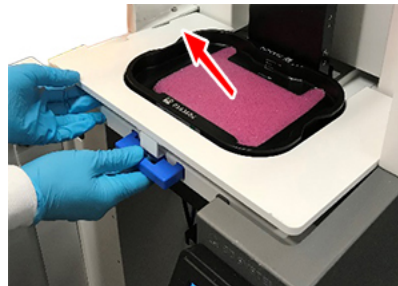

3. You may remove partially cured print material and debris from the tray in one of two ways (please only choose 1):

a. Pour the contents of the tray over the tray corner into your hazardous waste container. The Resin Mixer may be used to guide print material and debris out of the tray.



CAUTION: Do NOT use the Platform Scraper to clean the resin tray, as it will easily puncture the resin-tray membrane.



b. Rather than discarding the print material, you may also choose to keep this print material in its bottle. Use a glass funnel or solvent-resistant plastic funnel, along with a 190 micron automotive paint filter, to pour the print material back into its ORIGINAL bottle. When the tray is almost empty, use the plastic resin mixer to guide the last bits out. Discard the filter, as well as the cured print material it picks out, according to all government regulations.

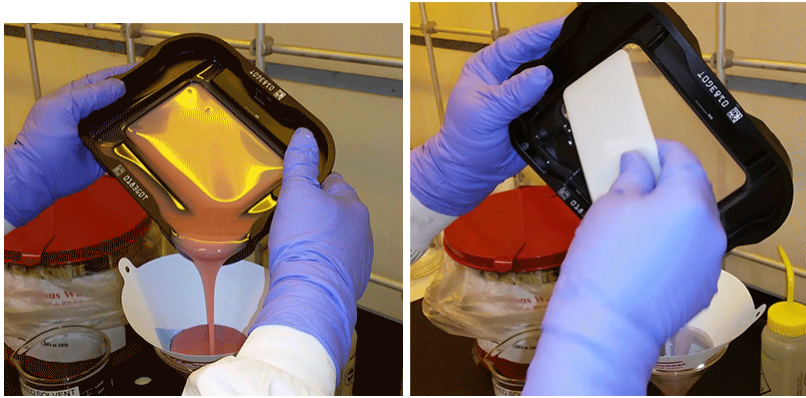

CAUTION: Do not pour print material into any bottle other than the one it came in. This is for two reasons: 1. The bottle has been designed to safely store resin without evaporation or curing inside; and, 2. You must scan the barcode on your bottle every time you print. Failure to scan the correct bottle will result in the machine storing incorrect levels of material remaining, as well as making it impossible for 3D Systems to track the material use should any print material issues arise.

4. Place resin tray in its garage.

Note: You may place a paper towel or clean-room wipe on your cleaning surface, so as not to get print material and/or solvent directly on it. This can also prevent foreign debris from dirtying or puncturing the tray's membrane. If you use this tip, be sure to discard the paper towel/wipe after each cleaning.

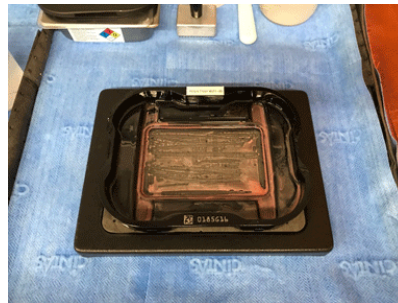

5. There are two different cleaning solvents you might use in this step, depending on which material was in the resin tray:

a. For any material EXCEPT for Figure 4 RUBBER-BLK 10: Pour approximately 250 mL of >90% alcohol into resin tray and use the Part-Cleaning Brush to gently agitate the material on the membrane and tray edges.

b. If cleaning Figure 4 RUBBER-BLK 10 out of the tray: Pour approximately 250 mL of Propylene Carbonate into resin tray and use the Part-Cleaning Brush to gently agitate the material on the membrane and tray edges. RUBBER-BLK 10 has some material components that do not dissolve in >90% alcohol. Do not use >90% alcohol for this step.

6. After brushing all surfaces that were in contact with resin, discard dirty solvent according to all government regulations.

7. Rinse the resin tray with clean >90% alcohol solvent and discard solvent according to all government regulations. It is okay to use alcohol for RUBBER-BLK 10 in this step.

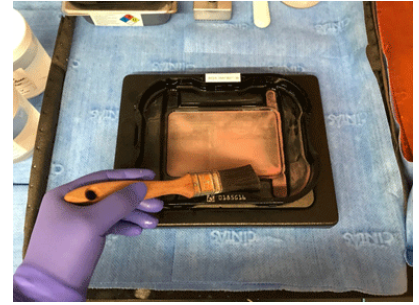

8. Dry membrane gently with 30 psi dry compressed air using an air gun attachment, or allow tray to air dry.

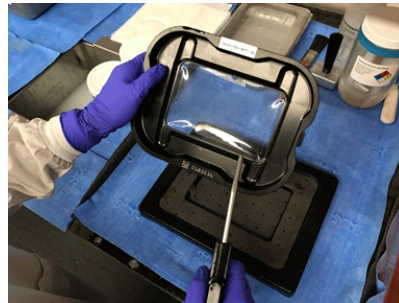

9. If uncured print material remains within the tray, repeat steps 5-8.

10. If uncured print material remains on the outer edges of the resin tray:

a. Wipe clean with a lint-free paper towel soaked with >90% alcohol (~15mL). Dispose of used paper towels and gloves discard according to all government regulations.

b. Dry membrane gently with 30 psi dry compressed air using an air gun attachment, or allow tray to air dry.

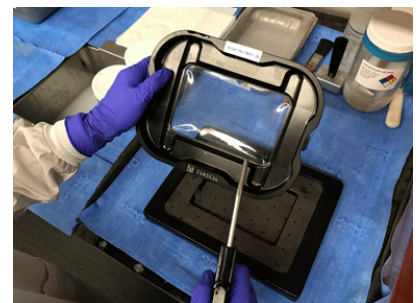
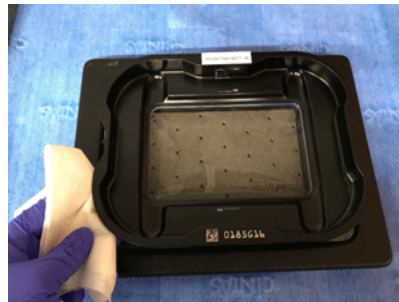

11. Inspect the resin tray to ensure no uncured resin and/or foreign debris remain.

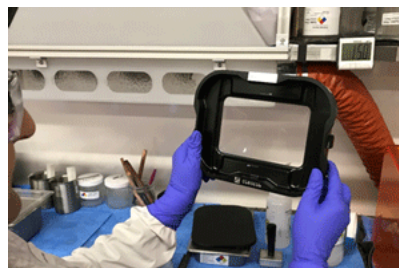

12. Discard all paper towels/wipes used throughout this procedure according to all government regulations.

The resin tray can now be stored in the Resin-Tray Garage or filled with new resin for printing.



→

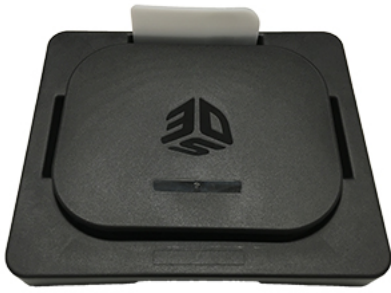

You can also store the resin tray in the printer with the cover from the garage on top, as seen below.



9.9 Figure 4 Standalone Clean Finishing Tools

It is necessary to clean any tools you used during post-processing before their next use, even if you are continuing to use the same resin. Items to be cleaned include:

1. Punch Tool
2. Resin Mixer
3. Platform Scraper
4. Part-Cleaning Brush
5. Your own tools

To clean any of these items, you can either soak them in IPA or place them into a beaker of IPA and put them in an ultrasonic cleaner. Ensure that they are completely dry before their next use, either by using compressed air or letting them air dry.

10 FIGURE 4 STANDALONE PRINTER ERROR MESSAGES



Note: Error codes are supported in firmware v1.1.1 or higher.

You might experience certain error messages during printer operation, or if the printer detects issues with printer components. Each error message will be accompanied by a numerical code, which you can use to look up troubleshooting steps in this guide.

ERROR CODE	ERROR TEXT	HOW TO CLEAR THE ERROR
3401100	Top Door Open, or Lower Door Open, or Catch Tray Missing Aborts the build? Yes Printer enters maintenance mode? No	Close top door, or Close bottom door, or Insert catch tray.
3401102	Operating temperature out of range Aborts the build? No Printer enters maintenance mode? No	Bring facility temperature in the range of 18-28°C (64.4-82.4°F).
3401106	Projector fault Aborts the build? Yes Printer enters maintenance mode? Yes	<ol style="list-style-type: none"> 1. Attempt printer reboot. 2. Contact your reseller.
3401107	Motor ttyUSB* device fault Aborts the build? Yes Printer enters maintenance mode? Yes	<ol style="list-style-type: none"> 1. Attempt printer reboot. 2. Contact your reseller.
3401108	Motor Communication Fault Aborts the build? Yes Printer enters maintenance mode? Yes	<ol style="list-style-type: none"> 1. Attempt printer reboot. 2. Contact your reseller.
3401110	Projector Serial Number Fault Aborts the build? No Printer enters maintenance mode? Yes	Contact your reseller
3401111	Halo Flash Factory Incomplete Fault Aborts the build? No Printer enters maintenance mode? Yes	Contact your reseller
3441201	Software Update Failed Aborts the build? No Printer enters maintenance mode? No	<ol style="list-style-type: none"> 1. Re-send upgrade to the printer. 2. Contact your reseller.
3441202	Software Update Not Found Aborts the build? No Printer enters maintenance mode? No	<ol style="list-style-type: none"> 1. Re-send upgrade to the printer. 2. Contact your reseller.
3441203	Upgrade file has bad encryption Aborts the build? No Printer enters maintenance mode? No	<ol style="list-style-type: none"> 1. Re-download upgrade file and re-send to the printer. 2. Contact your reseller.

ERROR CODE	ERROR TEXT	HOW TO CLEAR THE ERROR
3441204	Upgrade file has bad file format Aborts the build? No Printer enters maintenance mode? No	<ol style="list-style-type: none"> 1. Re-download upgrade file and re-send to the printer. 2. Contact your reseller.
3441205	Upgrade file has mismatched module count Aborts the build? No Printer enters maintenance mode? No	<ol style="list-style-type: none"> 1. Re-download upgrade file and re-send to the printer. 2. Contact your reseller.
3441207	Upgrade recovery failed Aborts the build? No Printer enters maintenance mode? No	Contact your reseller
3442100	External USB - no valid partitions Aborts the build? No Printer enters maintenance mode? No	<ol style="list-style-type: none"> 1. Use a USB drive with ext, FAT or NTFS formats. 2. Contact your reseller
3442101	External USB - corrupted Aborts the build? No Printer enters maintenance mode? No	<ol style="list-style-type: none"> 1. Reformat the USB (FAT or NTFS) or insert a non-corrupted USB drive. 2. Contact your reseller
3442102	External USB - empty Aborts the build? No Printer enters maintenance mode? No	USB must contain .ddd (firmware) or .f4x (3D Sprint) files
3480101	Barcode scanner absent Aborts the build? No Printer enters maintenance mode? No	<ol style="list-style-type: none"> 1. Attempt printer reboot. 2. Contact your reseller.
3480100	Barcode scanner HW error Aborts the build? No Printer enters maintenance mode? No	Re-scan the barcode.
3480102	No barcode detected Aborts the build? No Printer enters maintenance mode? No	<ol style="list-style-type: none"> 1. Reattempt scanning, using valid 3D Systems bottle label. 2. Reattempt scanning. 3. Check bottle label is clear. 4. Check bar code scanner window is clean.
3480103	Invalid barcode/Bottle not in MQG Server Aborts the build? No Printer enters maintenance mode? No	<ol style="list-style-type: none"> 1. Reattempt scanning, using valid 3D Systems bottle label. 2. Reattempt scanning. 3. Check bottle label is clear. 4. Check bar code scanner window is clean.
3480104	Unsupported barcode format Aborts the build? No Printer enters maintenance mode? No	Use the most-up-to-date bottle label. Contact your reseller for more information.

ERROR CODE	ERROR TEXT	HOW TO CLEAR THE ERROR
3480105	Expired barcode Aborts the build? No Printer enters maintenance mode? No	Use unexpired bottle.
3480106	Offline usage exceeded Aborts the build? No Printer enters maintenance mode? No	Printer needs internet connection to be able to reach the Material Quality Guarantee (MQG) server.
3492193	Z Axis Motor Stall Aborts the build? Yes Printer enters maintenance mode? Yes	Contact your reseller.
3492204	SATA drive not mounted Aborts the build? No Printer enters maintenance mode? No	Contact your reseller.
3493196	Material Recalled Aborts the build? No Printer enters maintenance mode? No	Contact your reseller.
3490111	Printing Aborted due to Bad File Aborts the build? Yes Printer enters maintenance mode? No	<ol style="list-style-type: none"> 1. Reboot printer. 2. Re-send file to the printer.
3490112	Print Aborted due to Internal Error Aborts the build? Yes Printer enters maintenance mode? No	<ol style="list-style-type: none"> 1. Reboot printer. 2. Re-send file to the printer.
3490113	Print Aborted due to Bad Print Setup Aborts the build? Yes Printer enters maintenance mode? No	Contact your reseller.
3490115	Printer LAN cable disconnected Aborts the build? No Printer enters maintenance mode? No	Check printer's ethernet cable connection.
3490116	NTP server unreachable Aborts the build? No Printer enters maintenance mode? No	<ol style="list-style-type: none"> 1. Check printer's ethernet cable connection and LAN settings. 2. Contact your reseller.
3490117	No internet connection Aborts the build? No Printer enters maintenance mode? No	<ol style="list-style-type: none"> 1. Check printer's ethernet cable connection and LAN settings. Ensure that your printer's IP address is white listed on your firewall. 2. Contact your reseller.
3490118	3DS MQG Server unreachable Aborts the build? No Printer enters maintenance mode? No	<ol style="list-style-type: none"> 1. Check printer's ethernet cable connection and LAN settings. Ensure that mqg.3dsystems.com is white listed on your firewall. 2. Contact your reseller.

ERROR CODE	ERROR TEXT	HOW TO CLEAR THE ERROR
3490119	3DS Manage Server unreachable Aborts the build? No Printer enters maintenance mode? No	<ol style="list-style-type: none"> 1. Check printer's ethernet cable connection and LAN settings. 2. Contact your reseller.
3490120	3D Connect Server unreachable Aborts the build? No Printer enters maintenance mode? No	<ol style="list-style-type: none"> 1. Check printer's ethernet cable connection and LAN settings. 2. Contact your reseller.
3490121	Printer not registered with Hydra Aborts the build? No Printer enters maintenance mode? No	Contact your reseller.
3490122	Printer does not have valid IP address Aborts the build? No Printer enters maintenance mode? No	<ol style="list-style-type: none"> 1. Reset IP address. 2. Contact local IT if IP is dynamic. 3. Contact your reseller.
3490123	Printer does not have valid primary and secondary DNS configuration Aborts the build? No Printer enters maintenance mode? No	<ol style="list-style-type: none"> 1. Reset IP address. 2. Contact local IT if IP is dynamic. 3. Contact your reseller.

11 FIGURE 4 STANDALONE SERVICE AND SUPPORT

Should any questions or issues arise, please contact 3D Systems as listed below.

[Customer Support Hotline](#)

General

Figure 4 Standalone Printer service procedures must be performed only by a 3D Systems-certified service technician unless this guide explicitly states otherwise. If your 3D printer system needs service, contact 3D Systems Technical Support at the following numbers:

- In the United States or Canada, call 800-793-3669
- In Europe, call +49-6151-357357

You can also contact your local 3D Systems representative.

3D Systems' support portal is located at <http://www.3dsystems.com/support>

For material safety data sheets of 3D Systems' resins, go to <https://support.3dsystems.com/s/article/materials-materials>

12 FIGURE 4 STANDALONE PREVENTATIVE MAINTENANCE

To keep the Figure 4 Standalone Printer in proper working order, it is necessary to perform certain procedures for preventative maintenance. The operator can perform these tasks without the supervision, or services, of a certified 3D Systems field engineer. The following section describes the most up-to-date preventative maintenance procedures.



CAUTION: Before performing any preventative maintenance procedures, power the printer down using the power switch on the back and disconnect printer power by unplugging the power cord from the back of the machine.

12.1 Cleaning the Printer

Frequency: Monthly

The external and internal parts of the printer should be cleaned according to the guidelines in the following sections. Here is a quick overview:

1. Clean the flooring/walls/surfaces around the printer with isopropyl alcohol (IPA) to ensure that any resin drips have been wiped up. For cleaning dust and other debris, use a small vacuum or other method that does not kick up dust clouds.
2. As needed, clean the outside Printer frame, EXCEPT FOR THE UPPER-BUILD-CHAMBER DOOR, with IPA and a nonabrasive cloth. Please see the section [Inspect Upper-Build Chamber Door](#) for instructions on cleaning it.
3. Use IPA and a nonabrasive cloth to clean elevator arms.
4. The following sections will give instructions on how to remove and clean more-specific parts of the printer. Please review all sections before cleaning your printer to ensure you are properly cleaning each component.

12.1.1 Clean-Replace the Catch Tray

Remove and Clean the Catch Tray

Frequency: Weekly

Once per week, remove the catch tray and clean it of dust or any drops of resin with a clean-room wipe and IPA as described below.

If there has been a significant leak from the resin tray, replace the resin tray and install the new catch tray that came with the new resin tray.



CAUTION: Do not attempt to use a catch tray after it has captured a significant spill of resin. It can be difficult to clean the glass well enough to ensure perfect transmission of the UV radiation to ensure good print quality. Instead, replace the catch tray. 3D Systems is not responsible for print quality failures due to a contaminated catch tray. Do not attempt to clean the catch tray while it is still inside the printer. The cleaning methods discussed below could cause damage to printer components if attempted inside the printer.



Wear Protective Gloves: ALWAYS WEAR 100% NITRILE GLOVES WHEN HANDLING THE CATCH TRAY, EVEN IF IT APPEARS THERE IS NO RESIN ON THE OUTSIDE OF IT. Getting fingerprints or other debris on the catch-tray GLASS can degrade print quality. remove/hold the tray with both hands and upright to prevent spilling.

1. Carefully pull the catch tray toward you until it comes off its track. Keep the tray upright at all times while pulling it out of the machine.



2. If the catch tray glass is visually clean of dust and resin drips, skip to the section [Replace the Catch Tray](#) below. If the catch-tray glass has normal dust or other debris on it, proceed to Step 3. If only the catch-tray reservoirs have resin in them, proceed to Step 4. If the catch-tray glass only has a few drops of print material on it, proceed to Step 5.



CAUTION: Do NOT reuse print material that has spilled into the catch tray. Spilled material is no longer viable for printing, as contaminants could have mixed with it.

3. You may use any of the following methods to clean dust or other debris off the catch tray:

- a. Use shop air to blow debris off both sides of the catch-tray glass. Be sure you clean both sides.
- b. Use a non-ammonia-based glass cleaner and a nonabrasive cloth to remove finger prints or other debris that is not print material. Be sure to clean both sides of the glass. After cleaning, use shop air or give the glass plenty of time to air dry before reinstalling.

4. To clean spilled resin in the catch tray and discard it:

- a. Pour out and discard the resin in the catch tray according to all government regulations.
- b. Hold the catch tray over a drip pan and squirt IPA into the catch tray, tilting the tray so that all waste material comes out.
- c. Use a nonabrasive cloth or lint-free paper towel to dry the inside of the catch tray.
- d. Discard the catch tray and all waste products according to all government regulations.

5. To clean spots of resin on the catch-tray glass

- a. Pour IPA onto a nonabrasive cloth such as a clean-room wipe.
 - b. Wipe the glass inside the catch tray until no more resin exists.
 - c. Turn the catch tray over and, using a new cloth sprayed with IPA, wipe the glass on the bottom of the catch tray.
 - d. Use shop air or give the glass plenty of time to air-dry before reinstalling.
6. Inspect the catch tray, ensuring that the glass plate has not detached or become damaged during cleaning.



Catch tray with clean glass

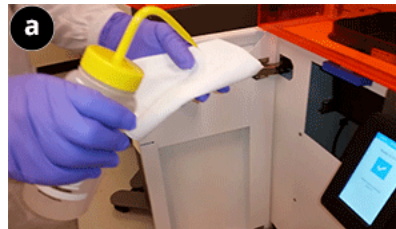

Replace the Catch Tray

Use the following instructions to reinsert the catch tray into the printer or to install a new catch tray.



CAUTION: Operating the printer without a catch tray installed risks getting material on the print-engine components, and risks over-curing of the printed parts, as the projector's radiation is filtered slightly by the catch-tray glass. Printing without a catch tray installed will also slightly alter the size of printed parts.

1. Line up the catch tray on the rails.

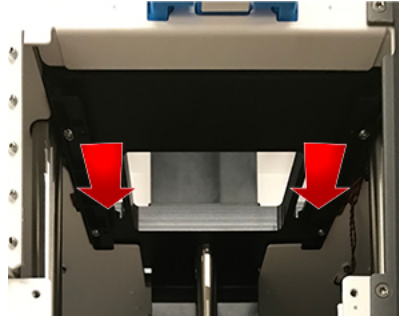

2. Hold up the catch tray, flush with the underside of the chassis, and push it toward the back of the printer until it stops at the back of the rails. See the picture below for the correct orientation to install the catch tray.

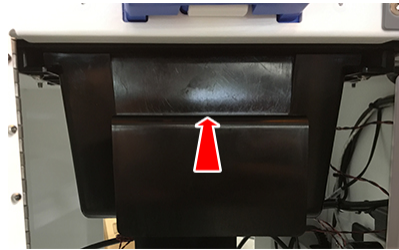
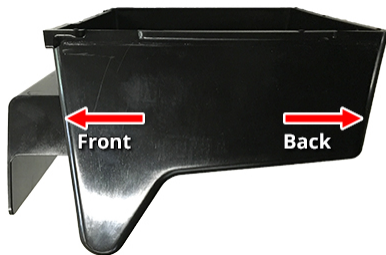

3. Push gently against the front of the catch tray to ensure that it does not go back any more and is fully seated in the machine.

12.1.2 Clean Resin Tray

Frequency: When changing materials, or monthly if using same material

If you haven't cleaned the resin tray in between builds, you must at least clean it periodically. Please follow the instructions in the section [Figure 4 Standalone Clean Resin Tray](#) to do so.



CAUTION: Failure to clean the resin tray regularly risks having partially cured resin bits in the tray, which can cause resin-tray membrane punctures and build failures.

12.1.3 Clean Tension System

Frequency: Monthly

You must periodically clean the tension latches on the left and right sides of the chassis.



Wear Protective Gloves: ALWAYS WEAR 100% nitrile gloves throughout this procedure.

1. Untension the resin tray and carefully remove it. Place it in the resin-tray garage with the lid on.



2. Remove both vanity covers from the printer chassis. Clean the vanity covers with a nonabrasive cloth and IPA.

3. Pour IPA on a nonabrasive cloth. Clean both latches and inspect them for any signs of damage. If there is damage, contact 3D Systems Service.
4. Clean the top and bottom of the tension arm itself with IPA. Inspect the tension arm for any signs of damage. If there is damage, contact 3D Systems Service.
5. Reinstall the vanity covers over the chassis.

Cleaning of the tension system is now complete.

12.1.4 Clean Membrane Interface Lip

Frequency: Weekly

The membrane interface lip is pictured below. It is the part of the chassis that makes contact with the resin-tray membrane.

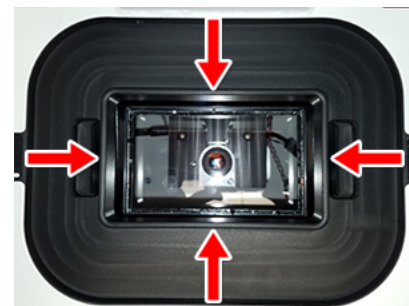

If the lip has dust, debris, or resin on it, clean it with IPA and a nonabrasive cloth. Inspect the lip for any damage, as chips or cracks could affect the tension of the resin-tray membrane during printing.

12.1.5 Clean Touch Screen and QR-Code Scanner

Frequency: Monthly

1. Ensure that the printer's touch screen does not have resin, dust, or other debris on it. If it does, pour IPA on a nonabrasive cloth and wipe the screen down.



2. Ensure that the QR-Code Scanner's window does not have resin, dust, or other debris on it. If it does, pour IPA on a nonabrasive cloth and wipe the screen down. You will not have access to clean behind the scanner's window. If you see that resin and/or debris has gotten inside the scanner window, contact 3D Systems Service.

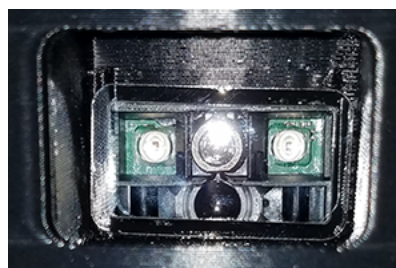

12.1.6 Inspect Printer Lid

Frequency: Monthly

Inspect Dust Seals

There are strips of dust-sealing material around the underside of the printer lid. These strips must remain intact to avoid dust and other debris entering the print chamber. There are seven strips in total, as indicated below. If ANY of these strips is damaged or removed, cease printing until the strip is replaced.

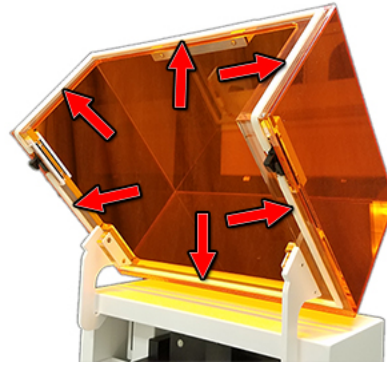

Inspect Printer Lid for Damage

Ensure that there is no damage to the printer lid that could hinder the printing process. Normal scratches are okay. Look for:

1. Cracks in the lid's plastic. Any cracks could expose the printing area to ambient UV light, which could affect part quality and could also cure material in the resin tray.
2. Breaks that do not allow the lid to close completely. If the lid does not fully close, the printing area could be exposed to ambient UV light.
3. Breaks that do not allow the lid to stay open when lifted. This type of break will make many print processes more difficult and prone to error.

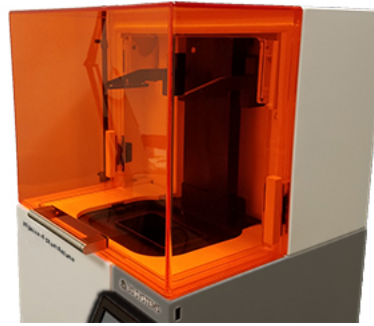

If any of these conditions is found to exist, contact 3D Systems Service for replacement information.

Clean Lid

The printer lid is made of acrylic and must be cleaned with a specialty product such as Novus No. 1 or Brilliance. A mild solution of soap or detergent and water can also be safely used. NEVER use window-cleaning fluids with ammonia (such as Windex or Formula 409), gasoline, denatured alcohol, carbon tetrachloride, or acetone, which will cause the acrylic to crack. It is best not to have a print platform or resin tray installed during lid cleaning, so as not to contaminate either with the cleaner you are using.

1. Apply the cleaning product with a damp, nonabrasive, lint-free cloth. Using a microfiber cloth or cellulose sponge is also acceptable.
2. Rinse with a nonabrasive cloth and clear, clean water.
3. Blot-dry with a chamois, damp cellulose sponge, or microfiber cloth to prevent water spotting



Note: Grease, oil, and tar may be removed with a good grade of hexane, naphtha or kerosene. Be sure to wash these solvents off quickly to prevent damage to the acrylic.

12.2 Inspect Projector Lens and All Cables

Frequency: Every two weeks

1. Ensure that the power cable is in good shape. If the cable is damaged and/or any wiring is exposed, cease use of the printer and order a new power cable.

1.

2. Ensure the Ethernet cable is in good shape and that it still connects tightly on the network port of both the printer and your Ethernet outlet. If this cable is damaged and/or wiring is exposed, cease use of printer and replace Ethernet cable.

Inspect the area around both wired connections for dust collection and other debris. Keeping these areas clean will prevent a static hazard and potential damage to the printer.

3. Clean the projector lens every two weeks or as needed. Use a clean-room swab and >90% IPA to wipe the projector lens of any dust. Be sure to wet the clean-room swab with the IPA, rather than squirting IPA directly onto the lens. Wear 100% nitrile gloves whenever handling IPA.



CAUTION: Do not use the printer if resin has spilled onto the projector, rather than just the lens. Do not attempt to clean the projector. Contact your reseller immediately.

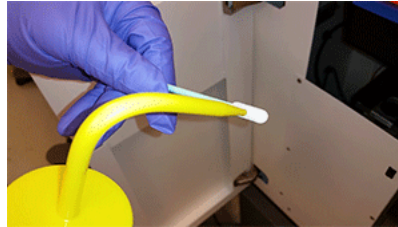

12.3 Check Printer Level

Frequency: Every three months

It is necessary to periodically check that the printer is still level relative to the chassis, whether it is on the pedestal or not.

Place bubble level on chassis, as seen at the right. If the bubble is not in the center of the circle, follow the steps in the section [Level the Printer on Pedestal](#).

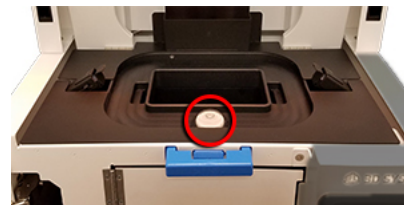

12.4 Check Print Platform Level

Frequency: As needed

If the print surface on the print platform is not level, it will affect the quality of your builds and may even lead to build failure. If a print platform is not level, it cannot be reliably bent to be made level and must be discarded according to all government regulations. This section describes how to identify the two ways in which your platform might be bent.

Identify a Convex Print Platform

1. Place the print platform, print-surface down, on a level surface.
2. Place a spacer of some kind that is between 0.5mm - 0.75mm thick (such as a credit card, shim, or washer) on the same level surface next to the platform.



Note: This test will be more accurate the closer your spacer is to 0.5mm.

3. Slide the spacer against one corner of the platform and ensure that the spacer does NOT fit underneath. If the spacer does fit underneath, the platform is convex on that corner.

4. Perform this check for each corner of the platform. If the spacer fits under any corner, the platform is convex and must be discarded.

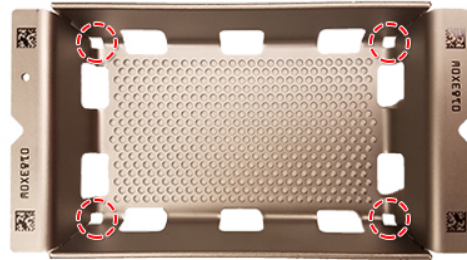

Identify a Concave Print Platform

1. Obtain a small spacer between 0.5mm - 0.75mm thick, such as a round shim or washer. Place the spacer on a level surface.
2. Place the print platform, print-surface down, on top of the spacer such that the spacer is in the center of the platform.

3. Gently push down on each of the four sides of the platform, one-at-a-time, and ensure that the platform rocks in the direction you are pushing. If the platform does NOT rock, it is an indication that the platform surface is concave.



Shown upside-down for clarity

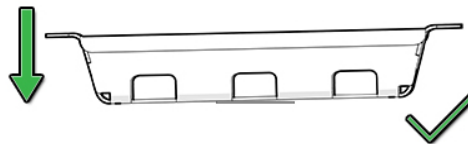

Good test - the platform tilts and is NOT concave. It may be reused.

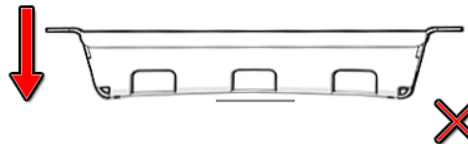

Bad test - the platform does not tilt and is concave. It may NOT be reused. Platform bend in this image is exaggerated for clarity.

12.5 Preventative Maintenance Checklist

This checklist is designed to help you keep up to date with regular printer maintenance. This is NOT an official document that must be submitted to your reseller; it is only for your information. Fill out the information in ALL the fields, and then press ctrl+P (cmd+P on Mac) to print the document. There is space at the bottom to sign and date if you wish to do so.

This is NOT an online form and is not submitted to any entity.

Company Name:

Maintenance Performer:

Date:

Weekly Items

Clean Membrane Interface Lip ([link](#))

Every 2 weeks

Only check box if performed this week. Otherwise, just fill in the date last performed.

Inspect Projector Lens and All Cables ([link](#)) - Last performed

Without removing the Catch Tray, Inspect Catch-Tray Glass for smudges/print material. Remove and clean if necessary ([link](#)). - Last performed

Monthly

Only check box if performed this week. Otherwise, just fill in the date last performed.

Clean Resin Tray ([link](#)) - Last performed

Cleaning the Printer ([link](#)) - Last performed

Clean Tension System ([link](#)) - Last performed

Inspect and Clean Printer Lid ([link](#)) - Last performed

Clean Touch Screen and QR-Code Scanner ([link](#)) - Last performed

Every 3 Months

Only check box if performed this week. Otherwise, just fill in the date last performed.

Change Air Filter ([link](#)) - Last performed

Check Printer Level ([link](#)) - Last performed

Every 6 Months

Only check box if performed this week. Otherwise, just fill in the date last performed.

Change Carbon Filter ([link](#)) - Last performed

Maintenance Performer Signature:

Date:

13 FIGURE 4 STANDALONE TROUBLESHOOTING

There are unique situations you may encounter when operating the printer. This section has compiled a partial list of these situations and methods of troubleshooting them.





Note: Unless troubleshooting steps require the printer to operate, shut down the printer and unplug it before performing troubleshooting steps.

General Issues

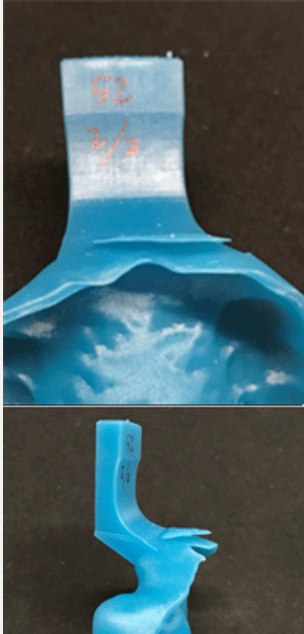

#	ISSUE DESCRIPTION	CUSTOMER TROUBLESHOOTING STEPS
GI1	Printer screen hangs on initialization screen	<ol style="list-style-type: none">1. Turn the printer off and unplug it. Wait ten seconds. Plug printer back in and turn it on.2. If problem persists, contact 3D Systems Service.
GI2	Printer screen freezes during operation	<ol style="list-style-type: none">1. Wait for the current print job to finish and move to the offload position. Remove the print platform from machine. Turn printer off and unplug it. Wait ten seconds. Plug printer back in and turn it on.2. If screen freezes again, contact 3D Systems Service.
GI3	3D Sprint will not install	<ol style="list-style-type: none">1. The downloaded installer file might be corrupted. Delete your installer file and download it again. If the installation is still not successful, contact 3D Systems Service.

13.1 Printed Part Quality

#	ISSUE DESCRIPTION	CUSTOMER TROUBLESHOOTING STEPS
PPQ1	Part not accurate in the X/Y direction	Run the Accuracy Wizard in 3D Sprint, as seen in the section Accuracy Wizard .

#	ISSUE DESCRIPTION	CUSTOMER TROUBLESHOOTING STEPS
PPQ2	<p>Delamination between layers - this is separation of printed layers, which do not cure together properly</p> 	<p>This can be caused by:</p> <ol style="list-style-type: none"> 1. Not enough material in the resin tray. To prevent this, be sure to fill material back up to the minimum level specified in this guide before building. 2. Tension latch down and resting on the springs but not engaged, membrane not tensioned. Check that latch is fully down. 3. Spilled print material or other debris gets in between the projector's radiation path and the print surface. In this case, remove the resin tray and catch tray and inspect them for spots of resin. <ol style="list-style-type: none"> a. Clean the resin tray, as in the section Clean Resin Tray . b. Follow the guidelines in the section Clean/Replace the Catch Tray to determine if your catch tray needs to be cleaned or replaced. c. Follow the guidelines in the section Inspect Projector Lens and Cables to determine if you can clean your lens, or if the resin spill is too wide-spread to clean with simple means. <p> CAUTION: Do not attempt to clean anything in the lower print chamber outside of what is listed in this guide. Doing so risks further damage to the printer. For large resin spills, contact your reseller immediately.</p> <ol style="list-style-type: none"> 4. The part orientation on the print platform can contribute to delamination. Please see the Figure 4 Best Practices to find out the best way to orient your part. 5. Resin-tray film scratched, dented, hazy/dirty- particularly in the failed area of the build. If scratched or dented, you must replace the tray. If hazy/dirty, clean the tray as in the section Clean Resin Tray .

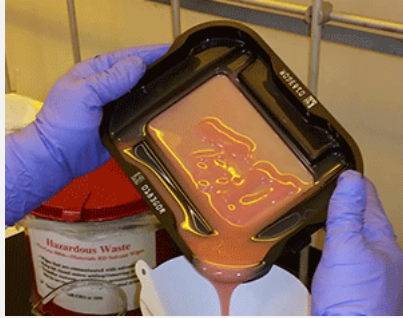
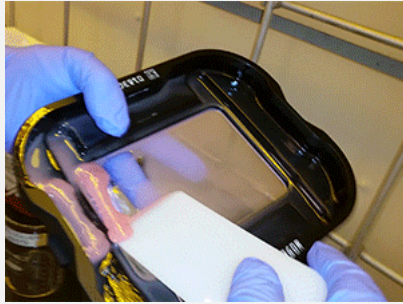
#	ISSUE DESCRIPTION	CUSTOMER TROUBLESHOOTING STEPS
PPQ3	Voids in printed part - holes or empty spaces where there shouldn't be	<p>This can be caused by:</p> <ol style="list-style-type: none"> 1. Not enough material in the resin tray. To prevent this, be sure to fill material back up to the minimum level specified in this guide before building. 2. Spilled print material or other debris gets in between the projector's radiation path and the print surface. In this case, remove the resin tray and catch tray and inspect them for spots of resin. <ol style="list-style-type: none"> a. Clean the resin tray, as in the section Clean Resin Tray . b. Follow the guidelines in the section Clean/Replace the Catch Tray to determine if your catch tray needs to be cleaned or replaced. c. Follow the guidelines in the section Inspect Projector Lens and Cables to determine if you can clean your lens, or if the resin spill is too wide-spread to clean with simple means. <div style="display: flex; align-items: flex-start; margin-top: 10px;"> <div style="margin-right: 10px;">  </div> <div> <p>CAUTION: Do not attempt to clean anything in the lower print chamber outside of what is listed in this guide. Doing so risks further damage to the printer. For large resin spills, contact your reseller immediately.</p> </div> </div> <ol style="list-style-type: none"> 3. <ol style="list-style-type: none"> a. This is not required if you completed Method B successfully. For Method A, perform the procedure in the section Running a Resin Tray Cleaning . b. This is not required if you completed Method A successfully. For Method B, empty the resin tray and clean the partially cured resin out. This method can be particularly useful if cured resin is fused to the resin-tray film, rather than just floating in the resin.

#	ISSUE DESCRIPTION	CUSTOMER TROUBLESHOOTING STEPS
		<p>i. Discard the resin in the resin tray according to all government regulations.</p>  <p>ii. Wearing 100% nitrile gloves, hold the resin mixer at the edge of the cured resin, while simultaneously gently pushing the cured resin from underneath the film. Use the resin mixer to gently scrape underneath the cured part to remove it.</p>  <p> CAUTION: Putting too much pressure on the resin-tray film can puncture the film. Be mindful of this during cleaning. The film cannot be replaced by itself; if the film is damaged, the whole resin tray must be replaced.</p> <p>iii. Clean the resin tray as described in the section Clean Resin Tray .</p>
PPQ4	Part color is incorrect	<p>Any one of the following could be the cause:</p> <ol style="list-style-type: none"> 1. Resin was not mixed in the bottle before pouring - Be sure to mix/stir the resin before printing according to the section Mixing, Stirring, and Curing Chart . 2. Resin was not stirred in the resin tray before printing - Be sure to mix/stir the resin before printing according to the section Mixing, Stirring, and Curing Chart . 3. A combination of both 1 and 2 - Be sure to mix/stir the resin before printing according to the section Mixing, Stirring, and Curing Chart . 4. You may have poured the wrong resin - Ensure that the resin you pour in the resin tray is from the same bottle you scanned. 5. You may have over-cured or under-cured the part - Ensure the part is cured as recommended in the Resin Stirring and Curing Chart . 6. You may not have cleaned the resin tray well enough before changing from one pigmented resin to another.

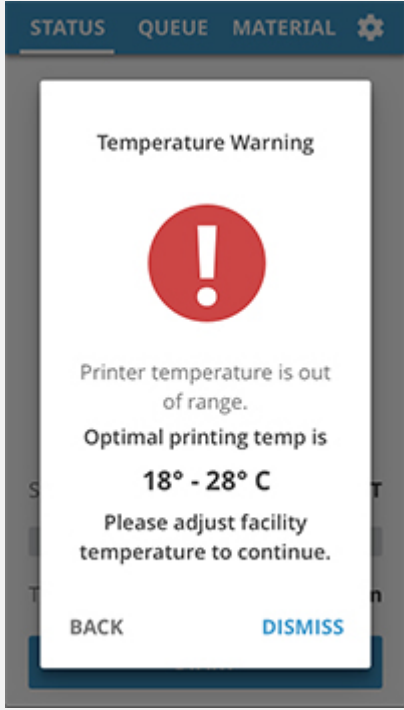
#	ISSUE DESCRIPTION	CUSTOMER TROUBLESHOOTING STEPS
PPQ5	Part does not adhere to the print platform	<p>This could be caused by:</p> <ol style="list-style-type: none"> 1. Dirty projector lens - Clean the lens according to the section Inspect Projector Lens and Cables . 2. Tension latch down and resting on the springs but not engaged, membrane not tensioned. Check that latch is fully down. 3. Dirty catch-tray glass - Clean the glass according to the section Clean/Replace the Catch Tray . 4. Debris on the print platform - partially cured resin from a previous build or other debris could prevent adhesion. Ensure you clean the print platform between each build as in the section Clean Print Platform .
PPQ6	Temperature warning on touch screen	<p>The optimal operating temperature of the printer is between 18°C-28°C (64°F-82°F). If you attempt to start a print job while the printer temperature is outside these limits, you will see the screen below. Adjust your facility's temperature to be within this acceptable range and, once this temperature has been reached, the message will disappear and you can continue printing. Tap the Cancel button to go back to the Pending Job screen.</p> 
PPQ7	Print does not start.	<ol style="list-style-type: none"> 1. Make sure to follow UI prompts. 2. If still experiencing issues, contact your reseller.
PPQ8	Part did not build.	<ol style="list-style-type: none"> 1. Ensure nothing is blocking the path of the projector's radiation to the bottom of the resin tray. 2. Ensure the build style used in 3D Sprint matches resin used in the print. 3. Ensure that Print Platform is seated correctly on elevator arms.
PPQ9	Part does not adhere to supports.	<ol style="list-style-type: none"> 1. Wrong support style - Please see 3D Sprint Best Practices 2. Not enough supports - Please see 3D Sprint Best Practices

#	ISSUE DESCRIPTION	CUSTOMER TROUBLESHOOTING STEPS
PPQ10	Pitting/Chalkiness	<p>Ensure part is cleaned and dried correctly before post-curing: See Part-Cleaning Procedure</p> <ol style="list-style-type: none"> 1. Do not leave part in alcohol solvent longer than recommended. See Part-Cleaning Procedure 2. Replace alcohol solution if saturated. 3. Spot clean hard to reach areas (engraving, small holes).
PPQ11	Line Defects	<ol style="list-style-type: none"> 1. Check for debris in resin. (if there is debris, run a resin-tray cleaning). 2. Check part orientation guide. Please see 3D Sprint Best Practices 3. Check support guide. Please see 3D Sprint Best Practices

13.2 Hardware Issues



Wear Protective Gloves: WEAR 100% NITRILE GLOVES WHENEVER HANDLING RESIN OR SOLVENTS.

#	ISSUE DESCRIPTION	CUSTOMER TROUBLESHOOTING STEPS
HW1	<p>Resin cures in the resin tray from ambient light sources.</p> 	<p>Ensure that you do not stage the printer in an area where it will be exposed to the following: Sunlight (even through windows), quartz-halogen lights, high-intensity incandescent lights, and other UV-intensive lighting. To clean cured resin out of the resin tray:</p> <ol style="list-style-type: none"> 1. Remove the resin tray from the machine. 2. If cured resin is on the upper lip of the tray, as in the picture at the left, use the Resin Mixer to scrape the cured material off. 3. If cured resin is in the main part of the tray, it will likely be floating on top as a thin film. You should be able to lift this film out wearing nitrile gloves. <p>In either case, you must discard the rest of the resin in the resin tray, as you will not have a way of knowing the amount this resin has cured. Discard the resin according to all government regulations.</p>
HW2	Resin Tray membrane is punctured or otherwise damaged.	The resin tray will have to be replaced. Contact your reseller to order more trays. It is a good idea to have at least one extra tray on-hand to reduce printer downtime.
HW3	Elevator Arms are loose	If elevator arms appear to be loose when placing a print platform on them, gently push on the arms in multiple directions to see if they shake. If they do, contact your reseller immediately. The printer will need to be sent in for repairs.

#	ISSUE DESCRIPTION	CUSTOMER TROUBLESHOOTING STEPS
HW4	Resin spills inside machine	<p>Resin spills in different parts of the machine will require different actions by the printer operator. Please find the scenario that matches your spill below:</p> <ol style="list-style-type: none"> Spilled resin is contained in the catch tray reservoirs, and no resin is on catch-tray glass - Remove the tray and dispose of the resin in the tray according to all government regulations. Rinse the catch tray out with IPA or EtOH and re-install in machine. <div data-bbox="1117 443 1516 674" data-label="Image"> <p>The image shows a black plastic catch tray with a white reservoir in the center. Two red arrows point upwards from the sides of the tray towards the reservoir, which is labeled 'reservoirs' in white text.</p> </div> Spilled resin hits the catch-tray glass - Follow the guidelines in the section Clean/Replace the Catch Tray to determine if your catch tray needs to be cleaned or replaced. <div data-bbox="1117 804 1516 1035" data-label="Image"> <p>The image shows a black plastic catch tray with a white reservoir in the center. The reservoir is labeled 'catch-tray glass' in white text.</p> </div> Spilled resin hits projector lens - Follow the guidelines in the section Inspect Projector Lens and All Cables to determine if you can clean your lens, or if the resin spill is too wide-spread to clean with simple means. <div data-bbox="1117 1192 1516 1713" data-label="Image"> <p>The image shows the internal projector lens assembly of the printer. Two red circles highlight the lens area, indicating where a resin spill might occur.</p> </div> <div data-bbox="938 1738 1024 1812" data-label="Image"> </div> <p>CAUTION: Do not attempt to clean anything in the lower print chamber outside of what is listed in this guide. Doing so risks further damage to the printer. For large resin spills, contact your reseller immediately.</p>

#	ISSUE DESCRIPTION	CUSTOMER TROUBLESHOOTING STEPS
		<p>4. Spilled resin hits components of the upper build chamber - If the resin has spilled on the orange lid (A), do NOT use IPA. Clean the lid according to the section Inspect Printer Lid . If the resin has hit any other component (B) besides the orange lid, clean the spill with IPA and a nonabrasive cloth.</p> 
HW5	Resin spills outside machine	<p>Resin spills outside the machine will require different actions by the printer operator. Please find the scenario that matches your spill below:</p> <p>Porous surfaces - These are surfaces that will absorb liquids. Examples of porous surfaces are: carpeting, unfinished wood, certain stone tiles/counters. It is not recommended to stage the printer on surfaces such as these, as resin cannot be reliably cleaned out of them. If resin spills on these, the recommendation is replace the affected sections of the surface.</p> <p>Non-porous surfaces - These are surfaces that will absorb little or no liquid. Examples of non-porous surfaces are: metal, glass, hard plastic, concrete, and finished wood. To clean spills on these surfaces, use paper towels to soak up as much resin as possible. Use IPA and paper towels to clean residual spilled resin. Discard all spilled resin and cleaning materials according to all government regulations.</p>
HW6	Touch screen touch input not working	<ol style="list-style-type: none"> 1. There may be resin buildup on the screen. Clean the screen with IPA and a nonabrasive cloth. 2. If Step 1 does not work, contact your reseller immediately. The printer will have to be sent in for repairs.
HW7	Machine makes noise; but touch screen is blank or off	<ol style="list-style-type: none"> 1. GUI computer might be frozen. Unplug printer and leave unplugged for 30 seconds. Plug printer back in and turn on. 2. If Step 1 does not work, contact your reseller immediately. The printer will have to be sent in for repairs.

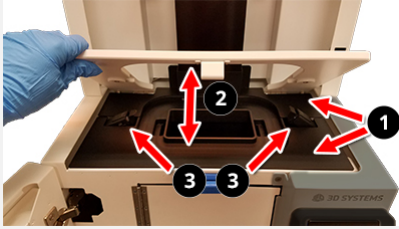
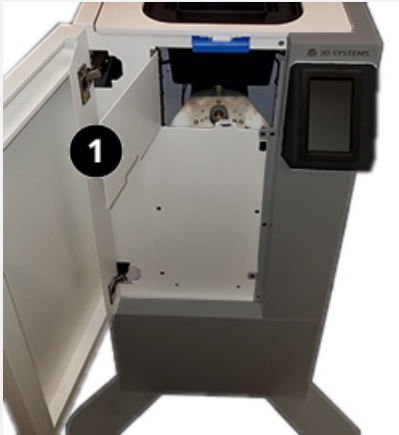
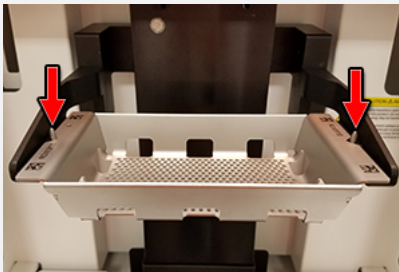
#	ISSUE DESCRIPTION	CUSTOMER TROUBLESHOOTING STEPS
HW8	Tension arm does not fully close	<ol style="list-style-type: none"> 1. Ensure that the vanity plates are properly seated on the chassis. Pay particular attention to the rear piece that partially covers the elevator. 2. Ensure there is nothing obstructing the underside of the tension arm or the top of the chassis. 3. Ensure that the tension clamps move freely and are unobstructed. 
HW9	Printer Lid does not close	<p>Ensure that the tension arm is fully closed. If the arm is raised or simply not fully locked into place, the lid will be hard to close or may not close at all.</p>
HW10	Printer Front Door does not close	<ol style="list-style-type: none"> 1. Ensure that the catch-tray access door (1) is fully closed. If the catch tray is not fully seated, this door cannot close- thus, the front door cannot close, either. Ensure that the catch tray is pushed all the way back. 2. Ensure there are no obstructions blocking the door from closing. 
HW11	Elevator Arms unable to lower the Print Platform onto the Resin Tray's membrane surface	<ol style="list-style-type: none"> 1. Ensure that the print platform is seated correctly on the elevator arms, with the triangular grooves of the platform fitting around the conical pins on the elevator arms. Ensure that no built-up resin or other debris are preventing this from happening. 2. Ensure that there is nothing obstructing the sides or back of the elevator spine that limits the motion of the elevator arms. 

#	ISSUE DESCRIPTION	CUSTOMER TROUBLESHOOTING STEPS
HW12	Barcode on bottle not scanning/Printer asks to "select previously scanned bottle"	<ol style="list-style-type: none"> 1. Ensure the QR code on your bottle is clear and does not have resin or other material on it that obstructs it. 2. Ensure the QR code scanner's window is clean of dust and debris. 3. Ensure your printer has an active internet connection. Scanning data is sent to a 3D Systems server for validation and the scanner will not operate correctly offline or on a closed network. 4. The printer might not be able to contact the QR-code-scanning server. Contact your network administrator and have him/her white-list the address mqg.3dsystems.com.

13.3 Part Cleaning Issues

#	ISSUE DESCRIPTION	CUSTOMER TROUBLESHOOTING STEPS
PCI1	Parts come out of cleaning process dirty, shiny, or sticky.	<ol style="list-style-type: none"> 1. Parts may not have been properly cleaned. Ensure you have followed all the steps in the sections under Cleaning Printed Parts . It is recommended that parts go through the cleaning process within 24 hours of printing. Some resins thicken as they sit over time and will require more vigorous cleaning. 2. Solvent baths may need to be changed. 3. Use solvent spray bottle and part-cleaning brush to rid the part of excess resin.
PCI2	Parts show surface cracks or edge erosion during sonication cleaning.	<ol style="list-style-type: none"> 1. Your particular print material may be sensitive to sonication power. Try one or more of the following: <ol style="list-style-type: none"> a. Reduce the power of your ultrasonic cleaner; b. Reduce the duration of sonication c. Reduce the temperature of the cleaner's tank. 2. If measures you took in Step 1 were not successful, clean printed parts manually. This process is referred to in the Cleaning Chart where it refers to "gentle shaking in sealed container."

#	ISSUE DESCRIPTION	CUSTOMER TROUBLESHOOTING STEPS
PCI3	Parts crack downstream after post curing.	<ol style="list-style-type: none"> 1. Parts may have been overexposed to solvents during cleaning. Ensure that you clean printed parts no longer than the times specified in the section Cleaning Parts Using an Ultrasonic Cleaner . 2. If your cleaning times were correct, there are other cleaning parameters that you can try changing: <ol style="list-style-type: none"> a. Reduce sonication power. b. If your ultrasonic cleaner's power setting cannot be changed, reduce cleaning time. c. Reduce temperature of liquid in ultrasonic cleaner. d. Increase drying time after cleaning.
PCI4	Supporting architecture not completely removed by hand	<ol style="list-style-type: none"> 1. Ensure that for future builds, you have removed the supporting architecture before post-curing the part(s). The post-curing process makes the supports stronger and, therefore, harder to remove. 2. Use tools such as flat snips and/or tweezers to remove support remnants from tight areas of your part. 3. Perform wet-sanding with IPA on support remnants.

13.4 Network Issues

#	ISSUE DESCRIPTION	CUSTOMER TROUBLESHOOTING STEPS
NI1	Computer unable to connect to printer because of network firewalls	Contact your network administrator. The printer's IP address must be added as an exception on your firewall. You can find the printer's IP address by going to the Settings tab on the touch screen.
NI2	Unable to use proxy server for connection	Proxy servers are not supported on this machine.
NI3	Unable to set static IP address from machine	<ol style="list-style-type: none"> 1. Please contact your network administrator to ensure you have a DHCP server and that it is set up correctly. 2. Ensure that DHCP is enabled in the printer settings.

#	ISSUE DESCRIPTION	CUSTOMER TROUBLESHOOTING STEPS
NI4	Printer unable to verify materials over network/Printer asks to "select previously scanned bottle"	<p>Contact your network administrator to ensure that:</p> <ol style="list-style-type: none"> 1. mqg.3dsystems.com (52.177.206.73) is made as an exception on your firewall. 2. www.3dsystems.com is made as an exception on your firewall 3. Your printer is on the internet via at gateway/NAT. 4. Ports 443 and 80 are open with encrypted connections. 5. If MQG is confirmed to be working, but your bottle still will not scan, check if NTP (Network Time Protocol) UDP port 123 is open on your network. If the printer's time of day is desynchronized, this will result in barcode-scan failure, even with an active internet connection. 6. See the Facility Requirements section of this guide for full network requirements.
NI5	Cannot connect to Internet via USB dongle	Internet connection via USB is not available on this machine.
NI6	I am not sure if my network cable is bad	Plug an Ethernet cable known to be working into the printer to test.

#	ISSUE DESCRIPTION	CUSTOMER TROUBLESHOOTING STEPS
NI7	Printer cannot be discovered by 3D Sprint	<ol style="list-style-type: none"> 1. Can the printer be added to 3D Sprint by entering the printer's IP address into 3D Sprint? If so, the printer may not be on the same subnet at the 3D Sprint PC - contact your network administrator. The same subnet is not required for 3D Sprint to connect to the printer, but is required for 3D Sprint to automatically discover printers. 2. If the printer cannot be added via IP address: Ensure UDP/TCP ports 30302 through 30320 and 60518 are open on your LAN (do not need to be open in the WAN firewall). 3. The printer may not have a valid IP or proper network configuration. (3D Sprint connection to the printer does not depend on Internet access) 4. If static IP is being used, be sure to use DHCP 5. Try to clean 3D Sprint database: <ol style="list-style-type: none"> a. Close 3D Sprint b. Open Documents folder c. Go to 3D Systems\3D Sprint -> this is the name of the 3D Sprint versions you are using d. Delete 3D Sprint.PrinterRegister file e. Go to PrinterDB folder f. Delete user.db file g. Start 3D Sprint and try to add the printer

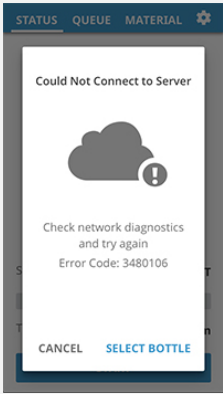
#	ISSUE DESCRIPTION	CUSTOMER TROUBLESHOOTING STEPS
NI8	<p>Various issues with scanning material bottles</p> 	<p>When you scan a material bottle, information is sent to 3D System's Material Quality Guarantee (MQG) Server. If your printer is having issues scanning material bottles, please work with your network administrator to complete the following troubleshooting steps:</p> <ol style="list-style-type: none"> 1. In a browser, on the same network as your printer, open https://mqg.3dsystems.com . If you see a blue page with the message Error 403 - Forbidden: Client certificate required, it confirms that your network is able to connect to MQG. 2. Use MQG Server Test.zip to verify MQG connectivity. Unzip the file and follow the attached instructions document in the zip file. 3. Check that the printer has the latest firmware version and go to the settings screen to verify that the printer is getting an IP address. <p>If this is a new printer installation:</p> <p>Your network configuration is not permitting external communication. See issue NI4, above for requirements.</p> <p>If you have been able to print before and this is a new error:</p> <ol style="list-style-type: none"> 1. Check your internet connection. 2. Your network configuration may have changed, such as new firewall rules. Ensure that the requirements from issue NI4, above, are all met. The printer may also have an invalid static IP configuration. Validate the configuration or switch the printer to DHCP mode. 3. MQG Server might be down. This server goes down for less than 15 minutes per quarter, and is monitored by 3D Systems' firmware team. 4. If the issue persists, contact your reseller.

#	ISSUE DESCRIPTION	CUSTOMER TROUBLESHOOTING STEPS																																																																																
NI9	Opening Network Ports	<ol style="list-style-type: none"> 1. In your web browser, visit the IP address of your router and sign into the admin menu. 2. Open the firewall settings and navigate to the settings for open ports. 3. Ensure all ports seen below are open. <table border="1" data-bbox="1089 453 1484 695"> <thead> <tr> <th>Name</th> <th>Port</th> <th>Protocol</th> <th>Status</th> <th>Action</th> </tr> </thead> <tbody> <tr> <td>30-Spnet-30002</td> <td>30002</td> <td>TCP/UDP</td> <td>Enabled</td> <td>Modify Delete</td> </tr> <tr> <td>30-Spnet-30003</td> <td>30003</td> <td>TCP/UDP</td> <td>Enabled</td> <td>Modify Delete</td> </tr> <tr> <td>30-Spnet-30004</td> <td>30004</td> <td>TCP/UDP</td> <td>Enabled</td> <td>Modify Delete</td> </tr> <tr> <td>30-Spnet-30005</td> <td>30005</td> <td>TCP/UDP</td> <td>Enabled</td> <td>Modify Delete</td> </tr> <tr> <td>30-Spnet-30006</td> <td>30006</td> <td>TCP/UDP</td> <td>Enabled</td> <td>Modify Delete</td> </tr> <tr> <td>30-Spnet-30007</td> <td>30007</td> <td>TCP/UDP</td> <td>Enabled</td> <td>Modify Delete</td> </tr> <tr> <td>30-Spnet-30008</td> <td>30008</td> <td>TCP/UDP</td> <td>Enabled</td> <td>Modify Delete</td> </tr> <tr> <td>30-Spnet-30009</td> <td>30009</td> <td>TCP/UDP</td> <td>Enabled</td> <td>Modify Delete</td> </tr> <tr> <td>30-Spnet-30010</td> <td>30010</td> <td>TCP/UDP</td> <td>Enabled</td> <td>Modify Delete</td> </tr> <tr> <td>30-Spnet-30011</td> <td>30011</td> <td>TCP/UDP</td> <td>Enabled</td> <td>Modify Delete</td> </tr> <tr> <td>30-Spnet-30012</td> <td>30012</td> <td>TCP/UDP</td> <td>Enabled</td> <td>Modify Delete</td> </tr> <tr> <td>30-Spnet-30013</td> <td>30013</td> <td>TCP/UDP</td> <td>Enabled</td> <td>Modify Delete</td> </tr> <tr> <td>30-Spnet-30014</td> <td>30014</td> <td>TCP/UDP</td> <td>Enabled</td> <td>Modify Delete</td> </tr> <tr> <td>30-Spnet-30015</td> <td>30015</td> <td>TCP/UDP</td> <td>Enabled</td> <td>Modify Delete</td> </tr> <tr> <td>30-Spnet-60016</td> <td>60016</td> <td>TCP/UDP</td> <td>Enabled</td> <td>Modify Delete</td> </tr> </tbody> </table>	Name	Port	Protocol	Status	Action	30-Spnet-30002	30002	TCP/UDP	Enabled	Modify Delete	30-Spnet-30003	30003	TCP/UDP	Enabled	Modify Delete	30-Spnet-30004	30004	TCP/UDP	Enabled	Modify Delete	30-Spnet-30005	30005	TCP/UDP	Enabled	Modify Delete	30-Spnet-30006	30006	TCP/UDP	Enabled	Modify Delete	30-Spnet-30007	30007	TCP/UDP	Enabled	Modify Delete	30-Spnet-30008	30008	TCP/UDP	Enabled	Modify Delete	30-Spnet-30009	30009	TCP/UDP	Enabled	Modify Delete	30-Spnet-30010	30010	TCP/UDP	Enabled	Modify Delete	30-Spnet-30011	30011	TCP/UDP	Enabled	Modify Delete	30-Spnet-30012	30012	TCP/UDP	Enabled	Modify Delete	30-Spnet-30013	30013	TCP/UDP	Enabled	Modify Delete	30-Spnet-30014	30014	TCP/UDP	Enabled	Modify Delete	30-Spnet-30015	30015	TCP/UDP	Enabled	Modify Delete	30-Spnet-60016	60016	TCP/UDP	Enabled	Modify Delete
Name	Port	Protocol	Status	Action																																																																														
30-Spnet-30002	30002	TCP/UDP	Enabled	Modify Delete																																																																														
30-Spnet-30003	30003	TCP/UDP	Enabled	Modify Delete																																																																														
30-Spnet-30004	30004	TCP/UDP	Enabled	Modify Delete																																																																														
30-Spnet-30005	30005	TCP/UDP	Enabled	Modify Delete																																																																														
30-Spnet-30006	30006	TCP/UDP	Enabled	Modify Delete																																																																														
30-Spnet-30007	30007	TCP/UDP	Enabled	Modify Delete																																																																														
30-Spnet-30008	30008	TCP/UDP	Enabled	Modify Delete																																																																														
30-Spnet-30009	30009	TCP/UDP	Enabled	Modify Delete																																																																														
30-Spnet-30010	30010	TCP/UDP	Enabled	Modify Delete																																																																														
30-Spnet-30011	30011	TCP/UDP	Enabled	Modify Delete																																																																														
30-Spnet-30012	30012	TCP/UDP	Enabled	Modify Delete																																																																														
30-Spnet-30013	30013	TCP/UDP	Enabled	Modify Delete																																																																														
30-Spnet-30014	30014	TCP/UDP	Enabled	Modify Delete																																																																														
30-Spnet-30015	30015	TCP/UDP	Enabled	Modify Delete																																																																														
30-Spnet-60016	60016	TCP/UDP	Enabled	Modify Delete																																																																														

14 REPACKING THE FIGURE 4 STANDALONE

If you are moving your printer to another facility in a vehicle, it is best to repackage the printer in its original packaging. If you did not keep your original packaging, contact your reseller to order a repacking kit. If you do not repackage the printer in its original packaging or in the packaging provided in the repacking kit, using the instructions in this section, you will assume liability for the printer in its move.

Repacking the Printer in its Original Packaging

1. Place the bottom cardboard piece on the pallet as shown at the right. Place bottom foam pieces in the orientation shown, leaving room on the right for the accessories box.

2. Place painter's tape around all door and lid seals as pictured.



CAUTION: Do not use any other tape besides painter's tape to seal the doors. This will ensure that your tape does not leave a sticky residue on the printer.

3. Team-lift the printer into place on the foam pieces, as shown. Place plastic sleeve and blue foam pieces over printer as shown.

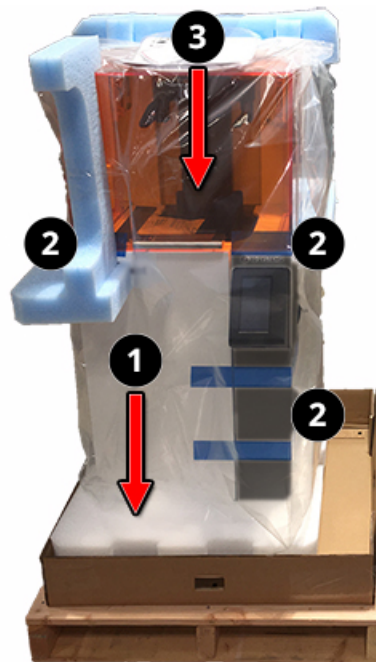

4. Place items in accessories box as seen at the right. Be sure to use bubble wrap or similar package-protection measures.

a. (bottom) Carbon Filter

b. (middle) Resin-Tray Garage

c. (top) Ethernet Cable

d. Nitrile Gloves

e. Print Platforms

f. Platform Scraper, Part-Cleaning Brush, Wire Brush, Resin Mixer, Bubble Level, Punch Tool

g. Resin Tray

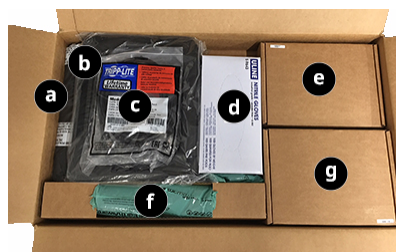

5. Place the accessories box in the long cardboard frame it originally came in. Use packing tape over it to secure it to the frame.



6. Place cardboard frame with accessories box next to the printer box on the pallet. It should fit snugly in the empty slot, with the accessories box facing outward.



7. Slide the outer box around the printer and accessories box.



8. Insert packing clips in the holes on all four sides of the printer package. Close the clips to lock them in place.



9. Use packing tape to seal the top of the box.

10. Secure the box to the pallet using packing belts.

Your printer is now ready to move to another facility!





CE 21

EC DECLARATION OF CONFORMITY (DoC)

We

Manufacturer: 3D Systems, Inc.
Address: 333 Three D Systems Circle Rock Hill, SC 29730

declare under sole responsibility for issuing this declaration of conformity in relation to the following Product(s):

Product Description: 3D Printer
Models: NextDent 5100, Figure 4 Standalone, and Figure 4 Jewelry
Serial Number: [Redacted]

For the above given Product(s) is hereby declared that it conforms to the essential requirements set out in community harmonization legislation mentioned below:

- Machinery Directive 2006/42/EC
Electromagnetic Compatibility Directive 2014/30/EU of 14 October 2014
Restriction of use of certain Hazardous Substances Directive 2011/65/EU of 7 January, 2011; Directive 2015/863 of 31 March 2015

Statement about the relevant harmonized standards that have been used, or statement about the specifications in relation to which conformity is declared (Standard: Date of Issue):

- EN 12100:2010
EN 61010-1:2010
EN 61326-1:2013
EN 61000-3-3:2013
EN 60204-1:2018
IEC 62471:2008
EN 61000-3-2:2014
EN 63000:2018

Name of Person Authorized to compile the technical construction file: Jasper Vandendriessche
Grauwmeer 14, 3001 Leuven, Belgium

Local contact for regulatory topics only:
North America: 3D Systems, Inc, 333 Three D Systems Circle, Rock Hill, SC 29730, USA
Europe: 3D Systems-Leuven, Grauwmeer 14, 3001 Leuven, Belgium

Signed for and on behalf of:

San Diego, CA, USA Place of issue
July 14, 2021 Date of issue
Doug Hoffman, Engineering Director

© by 3D Systems, Inc. All rights reserved. Specifications subject to change without notice. 3D Systems, the 3D Systems logo are registered trademarks and Figure 4 Standalone and Figure 4 are trademarks of 3D Systems, Inc.



3D Systems, Inc. 333 Three D Systems Circle | Rock Hill, SC | 29730 www.3dsystems.com

Rev. P, P/N 42-D115



3D Systems, Inc. 333 Three D Systems Circle Rock Hill, SC 29730
www.3dsystems.com

Register Statement

© 2023 by 3D Systems, Inc. All rights reserved. Specifications subject to change without notice. 3D Systems and the 3D Systems logo are registered trademarks of 3D Systems, Inc.

Copyright © 3D Systems, Inc. All rights reserved. p/n 42-D115 Rev. P